



TKO

WELTERWEIGHT[®]

DOCK DOOR



User's Manual - Installation, Operations, Maintenance and Parts Listing

This manual applies to WelterWeight Dock Doors manufactured beginning May 2012

▲ WARNING

DO NOT install, operate or service this product unless you have read and understand the safety practices, warnings, installation and operation instructions contained in this manual. Failure to do so could result in death or serious injury.

© 2012 4Front Engineered Solutions, Inc.

15-00015 R10 05/12 WW

TABLE OF CONTENTS

LIMITED WARRANTY	1
OWNER'S RESPONSIBILITIES	2
TOOLS & MATERIALS	3
Recommended Anchor System for Hollow Block	3
SAFETY	4
Safety Signal Words	4
Safety Practices	4
SITE PREPARATION	6
Door Opening	6
Track Mounting Surface	8
TRACK ANCHORING APPROVED METHODS	10
Structure	10
TRACK INSTALLATION	12
Lower Track Installation	12
STEEL TRACK INSTALLATION	17
Straight Vertical Upper Track Installation	18
Tilt T1 Upper Track Installation	20
Tilt T2 Upper Track Installation	24
Roof Pitch Upper Track Installation	28
High-Lift Upper Track Installation	30
UW TRACK INSTALLATION	32
Straight Vertical Upper Track Installation	34
Tilt T1 Upper Track Installation	36
Tilt T2 Upper Track Installation	40
Roof Pitch Upper Track Installation	44
High-Lift Upper Track Installation	46
PANEL INSTALLATION	48
Component Identification	48
Panel Stacking	50
Slide Lock Installation	52
Lintel Seal Installation	52
Decals & Placard Installation	53
SPRING/SHAFT INSTALLATION	56
Center Spring Pad Installation	56
Component Identification	58
Single Spring/Single Shaft Assembly	58
Double Spring/Single Shaft Assembly	60
Double Spring/Split Shaft Assembly	62

TABLE OF CONTENTS (continued)

WINDING SPRINGS	64
Secure Door	64
Install Cables	64
Wind Springs	64
DOOR OPERATION	68
AVAILABLE OPTIONS	69
PLANNED MAINTENANCE	70
TROUBLE SHOOTING	71
PARTS LISTING	72



NOTES

LIMITED WARRANTY

THIS LIMITED WARRANTY IS TKO DOCK DOORS SOLE AND EXCLUSIVE WARRANTY WITH RESPECT TO THE DOCK DOOR AND IS IN LIEU OF ANY OTHER GUARANTEES OR WARRANTIES, EXPRESS OR IMPLIED.

TKO DOCK DOORS warrants that this DOCK DOOR will be free from flaws in material and workmanship under normal use for a period of ONE (1) year from the earlier of 1) 60 days after the date of initial shipment by TKO DOCK DOORS, or 2) the date of installation of the DOCK DOOR by the original purchaser, provided that the owner maintains and operates the DOCK DOOR in accordance with this User's Manual.

TKO DOCK DOORS warrants its WelterWeight Panels will remain operational after resetting from impact under normal use, service and maintenance for ONE (1) year (excluding any window portion thereof) from date of shipment. Does not cover punctures, cracks or slices in panel(s). Optional Super Panel: TWO (2) year performance limited warranty from date of shipment.

EXTENDED LIMITED WARRANTY

TKO DOCK DOORS warrants its optional "Impact-A-Track" for FIVE (5) years from date of purchase. This is a performance warranty and for the UHMW portion only. Cuts, gouges, and abrasions are not considered warrantable conditions.

In the event that this DOCK DOOR proves deficient in material or workmanship within the applicable limited warranty period, TKO DOCK DOORS will, at its option:

1. Replace the DOCK DOOR, or the deficient portion of either, without charge to the owner; or
2. Alter or repair the DOCK DOOR on site or elsewhere, without charge to the owner.

This limited warranty does not cover any failure caused by improper installation, abuse, negligence, or failure to maintain and adjust the DOCK DOOR properly. Parts requiring replacement due to damage resulting from abuse or improper operation are not covered by this warranty. ***This limited warranty does not include*** normal wear, modifications, and damage beyond the manufacturer's control, replacement labor or implied cycle life of counter balance system (cables, spring assemblies, drums, shaft cones and bearings, or center bearing brackets). TKO DOCK DOORS DISCLAIMS ANY RESPONSIBILITY OR LIABILITY FOR ANY LOSS OR DAMAGE OF ANY KIND (INCLUDING WITHOUT LIMITATION, DIRECT, CONSEQUENTIAL OR PUNITIVE DAMAGES, OR LOST PROFITS OR LOST PRODUCTION) arising out of or related to the use, installation or maintenance of the DOCK DOOR (including premature product wear, product failure, property damage or bodily injury resulting from use of unauthorized replacement parts or modification of the DOCK DOOR). TKO DOCK DOORS's sole obligation with regard to a DOCK DOOR that is claimed to be deficient in material or workmanship shall be as set forth in this Limited Warranty. This Limited Warranty will be null and void if the original purchaser does not notify TKO DOCK DOORS's warranty department within ninety (90) days after the product deficiency is discovered.

THERE ARE NO WARRANTIES, EXPRESS OR IMPLIED, WHICH EXTEND BEYOND THE DESCRIPTION ON THE FACE HEREOF, INCLUDING, BUT NOT LIMITED TO, A WARRANTY OF MERCHANTABILITY OR OF FITNESS FOR A PARTICULAR PURPOSE, ALL OF WHICH TKO DOCK DOORS HEREBY DISCLAIMS.

For questions regarding this warranty, services, or parts contact: TKO Customer Service at 1-800-575-3366.

OWNER'S RESPONSIBILITIES

THE OWNER'S RESPONSIBILITIES INCLUDE THE FOLLOWING:

- The owners should recognize the inherent danger of the interface between the dock and transport vehicle. The owner should, therefore, train and instruct operators in the safe use of the TKO Dock Door as well as all dock equipment devices.
- Nameplates, cautions, instructions and posted warnings shall not be obscured from the view of operating or maintenance personnel for whom such warnings are intended.
- Manufacturer's recommended periodic maintenance and inspection (procedures in effect at date of shipment) shall be followed, and written records of the performance of these procedures should be kept.
- Loading dock doors that are structurally damaged or have experienced failure shall be removed from service, inspected by the manufacturer's authorized representative and repaired as needed before being placed back in service.
- The owner shall see that all nameplates, caution and instruction markings or labels are in place and legible and that the appropriate operating and maintenance manuals are provided to users.
- Modifications or alterations of loading dock doors shall be made ONLY with the written permission of the original manufacturer.
- When industrial trucks are driven on and off transport vehicles during the loading and unloading operation, the brakes on the transport vehicle shall be applied and wheel chocks or positive restraints that provide the equivalent protection of wheel chocks engaged.

WARNING

DO NOT install, operate, or service this product unless you have read and understand the safety practices, warnings, installation and operation instructions contained in this manual. Failure to do so could result in death or serious injury.

TOOLS & MATERIALS

THE FOLLOWING TOOLS & MATERIALS ARE NECESSARY FOR PROPER INSTALLATION OF ANY TKO DOOR(S) AND ARE NOT PROVIDED BY TKO:

- Two Spring Winding Bars, approximately 24" (minimum) long for winding springs.
 - 1/2" diameter bars for 2-5/8" diameter springs.
 - 5/8" diameter bars for 3-3/4" and 6" diameter springs.
- Tools to mount track to wall using any of the recommend track anchoring methods:
 - Hammer Drill or Impact Wrench.
- Tools to mount track to wall using any of the alternate track anchoring methods:
 - Hammer Drill or Impact Wrench.
 - Welder with welding rods. Include grinder if door to be removed is welded to jambs.
- Aerial equipment: Ladders, scaffolding, scissors lift or boom lift.
- Hand tools: socket wrench set: 7/16", 1/2", 9/16", 4' long level, bar clamps or C-clamps, locking pliers/ vice grips, hammer, screwdrivers, and tape measure (contractor grade).
- Lubricants: Light Weight Oil for lubing Plunger Spring Shafts and Bearings, Torsion/Counterbalance Springs. Dry Silicone Spray for lubing tracks and side seals.
- Steel angle (minimum 12 gauge) for Backhangs and Sway Braces. Size will vary with different applications.
- Anchors/Fasteners used to mount tracks, center and end bearing plates, etc.
- Spring Mounting Pad(s) MUST BE structurally sound to support weight of Spring(s) and the torque put on them.

TKO Dock Doors DOES NOT supply Backhang Material, Spring Mounting Pads or Wall Mounting Hardware.

RECOMMENDED ANCHORS FOR HOLLOW BLOCK WALL

TKO recommends the following :

- 3/8"-16 Concrete Single or Double Expansion Shield Anchors.
- 3/8" Short Lag Shields.
- NOTE: Anchors must be those suitable per the manufacturer for use in hollow block wall, and installed per the manufacturer's instructions.

SAFETY

SAFETY SIGNAL WORDS

You may find safety signal words such as DANGER, WARNING, or CAUTION throughout this owner's manual. Their use is explained below.



This is the safety alert symbol. It is used to alert you to potential personal injury hazards. Obey all safety messages that follow this symbol to avoid possible death or injury.

▲ DANGER

Indicates an imminently hazardous situation which if not avoided, will result in death or serious injury.

▲ WARNING

Indicates a potentially hazardous situation which, if not avoided, could result in death or serious injury.

▲ CAUTION

Indicates a potentially hazardous situation which, if not avoided, could result in minor or moderate injury.

NOTICE

Caution used without the safety alert symbol indicates a potentially hazardous situation which, if not avoided, could result in property damage.

SAFETY PRACTICES

▲ WARNING

Read and follow these Safety Practices before installing, operating or servicing the door. Failure to follow the Safety Practices could result in death or serious injury.

If you do not understand the instructions, ask your supervisor to explain them to you, or call TKO at 1-800-575-3366, or ask qualified TKO door technician to assist.

Installation, Maintenance and Service

1. ONLY experienced and qualified door technicians should install or repair doors. Springs, cable brackets, cables, drums, plungers, supports and their hardware are under high tension and can cause injuries if not properly handled.
2. Use the proper type and capacity ladders, lifting equipment and safety straps or harnesses.
3. Safe and efficient installation requires a two-person crew.
4. Observe OSHA requirements for "LOCKOUT" or "TAGOUT" when performing work on doors.
5. Observe any/all overhead hazards such as electrical, air, process piping or HVAC ducting when working.
6. Move any dock leveler to the dock level storage position before using as a platform for ladders, lift trucks or other equipment used in the installation of the door.
7. Place barricades on the dock floor around the dock door and in the driveway in front of the door while installing, maintaining, or repairing the dock door.
8. If door is operated with any type of motor or automatic system, TKO highly recommends the use of a UL325 compliant entrapment protection device such as monitored safety edge or monitored photoeye.
9. Follow all local and state codes regarding attachment of back-hang to structural components of the building.

SAFETY (continued)

SAFETY PRACTICES (continued)

Operation

1. Personnel using the dock doors **MUST BE** properly trained.
2. Operate door **ONLY** when properly adjusted and free of obstructions. Should the door become difficult to operate or completely inoperative, immediately report to supervisor.
3. **DO NOT** stand or walk under moving door. Keep door in full view and free of obstructions while operating.
4. **DO NOT** allow children to operate the door or controls.
5. **DO NOT** throw door up violently. Using excessive force to open or close the door may cause the door cables to jump or door panels to disengage from tracks.
6. **DO NOT** close door onto obstructions. Obstructions in the opening may stop the doors movement and cause the door cables to jump or door panels to disengage from tracks.
7. To avoid injury, keep hands free of door parts while operating. Panels and door parts may create pinch points when in operation.
8. **NEVER** use damaged or malfunctioning dock door.

Resetting Impacted Panels

In the event of a panel KNOCK-OUT or track impact situation, step away from the door a safe distance.

7. Inspect the door system **BEFORE** resetting panels.
 - Plungers on the top panel **MUST BE** engaged in track.
 - Cables **MUST BE** properly tensioned and seated in the grooves of the cable drums.
 - Panels **MUST BE** sitting level with hardware intact.
 - Tracks **MUST BE** square to jamb face and securely mounted.If the above conditions are met, continue with resetting door (see steps 3-6 below). If any of these conditions are not met, **DO NOT** use door. Stay clear of door and immediately report incident to supervisor and have a trained door systems technician inspect and reset door.
8. Clear fork truck and/or all products from dock door area.
9. Grab manufacturer-supplied handle(s) and pull door panels back into tracks. If the spring plunger tips are obstructed at any point of the return travel, the plunger rods may be manually retracted while pulling panels back into tracks. Depending on conditions, this operation may require 2 people to safely reset the door.
 - **NEVER try to open or close door until all panel plungers are reset back into track and door has been inspected.**
 - **NEVER climb under impacted panels to reset door.**
10. Check panels, track, hardware and fasteners for any damage, looseness, misalignment, and verify track spacing **BEFORE** operating door.
11. After panels have been engaged back into the tracks, carefully cycle the door to its fully open and closed position several times making sure operation is smooth throughout its entire travel cycle.

WARNING

All TKO Dock Doors [except Straight Verticals (SV)] require Safety Spreader Bar cross bracing and Safety Cable Assemblies to be installed in the area from the header to the top end of panel travel per the installation instructions on pages 20 through 31 or 38 through 49 depending on track style. If the Spreader Bars are not installed, the Tracks may spread, if impacted, and allow the door to fall. Failure to follow these instructions could result in death or serious injury.

SITE PREPARATION

▲ WARNING

Before installing the door, read and follow the Safety Practices on pages 4 and 5. Failure to follow the Safety Practices could result in death or serious injury.

DOOR OPENING

1. For the TKO Knock-out Dock Door system to function properly, the door opening **MUST BE** 'true', 'square', 'plumb' and 'flush'. Any compromise of the door opening characteristics may affect the function and performance of the door. If jamb repair, replacement or adjustment is required, it is critical that the original door opening dimensions are maintained as listed in the original door specification sheet.
2. Measure DOOR OPENING WIDTH (DOW). The finished DOW **MUST** match the designed TRACK SPACING dimension as shown on the third panel. The door panels will not easily break away and reset properly when impacted, or the door panels may fall out of the tracks if the track spacing is not kept within +/- 1/4" of designed track spacing. Measure width at floor, mid jamb, and header to identify and correct any width variations.
3. Measure DOOR OPENING HEIGHT (DOH). Verify finished DOH matches the door height listed on the door spec sheet. Stacked door panels are designed for additional panel height above header for proper sealing. If the finished DOH exceeds the specified door height more than (3"), contact TKO Doors for assistance.
4. Check jambs with a level to ensure the jambs are square to door opening. Correct any jamb condition that will not allow the panels to break out properly.
5. Check jambs with a level to ensure the jambs are plumb and straight. The tracks **MUST BE** installed level while maintaining the specified track spacing. If the jambs are not level and straight, a portion of the jamb may be exposed (in relation to the track), restricting the panels from properly knocking-out.
6. Inspect jamb walls for any obstructions. Ensure that nothing will impede the door's outward movement when impacted. Any sharp edges **MUST BE** eliminated to prevent possible seal damage as panels swing into the opening when impacted.
7. TKO recommends the easy to install optional 3', 6' or Full Height Impact-A-Track™ to protect portion of the steel track from being damaged due to impacts. If the optional Impact-A-Track is not used, TKO recommends the use of pipe bollards for protection of the door tracks.

Contact TKO Doors for assistance at 1-800-575-3366.

SITE PREPARATION (continued)

DOOR OPENING

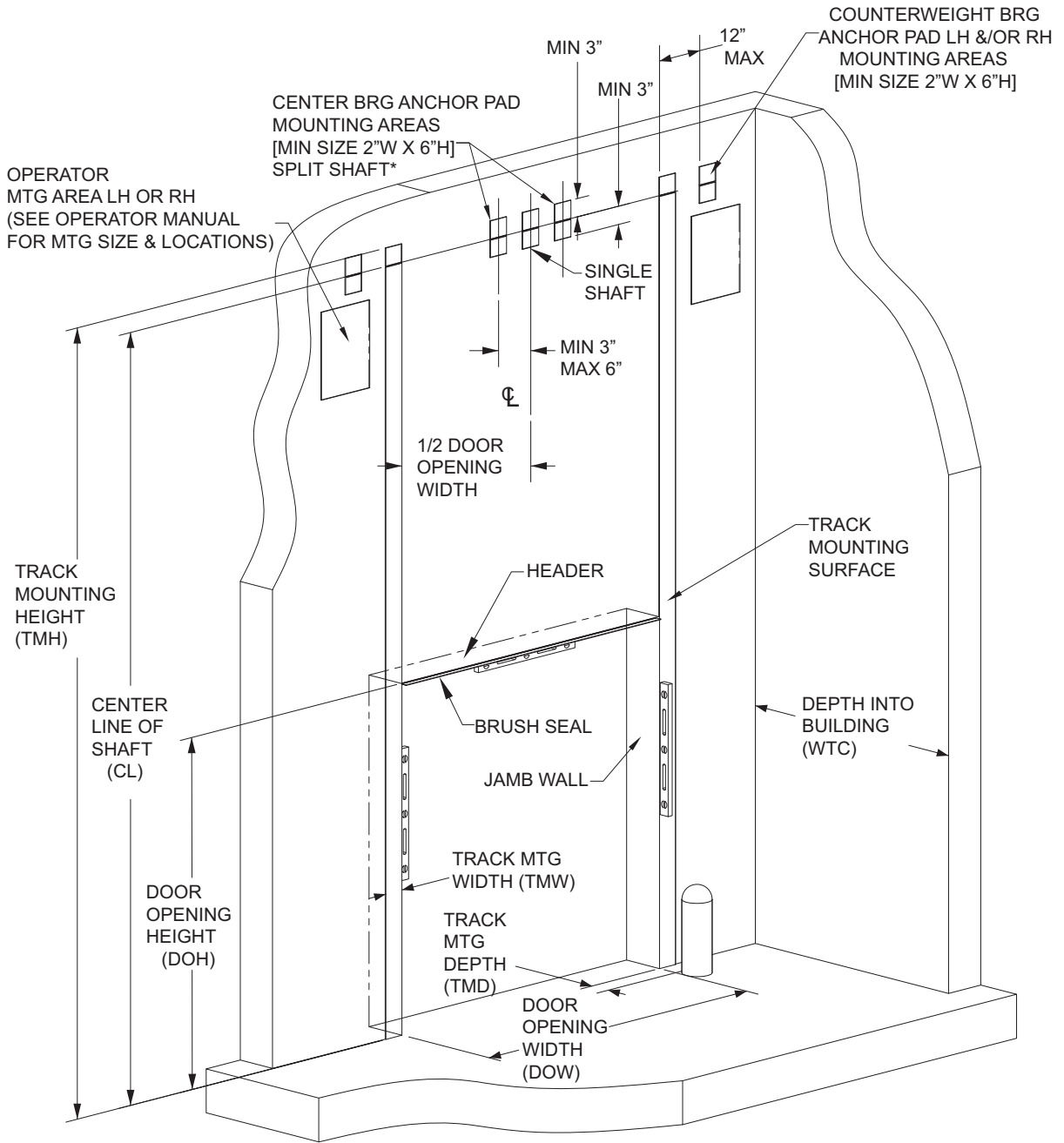

SITE PREPARATION (continued)

TRACK MOUNTING SURFACE

1. Measure available TRACK MOUNTING HEIGHT (TMH). Verify that the required TMH will fit in the available space. See job specific documents shipped with your order. If the required TMH exceeded what is available, contact TKO Doors for assistance.
2. Check door specification sheet for track mounting style and track print for TRACK MOUNTING WIDTH (TMW). Verify that the width of the mounting surface on jamb is equal or greater than the mounting width of the track.
3. Check TRACK MOUNTING DEPTH (TMD) for any obstructions such as a bollard or curb that would interfere with mounting the track to the jamb. Verify track depth on track print for track dimension. If track depth exceeds available space, contact TKO Doors for assistance.
4. Make sure all track-mounting surfaces, header beam and center bearing bracket pads are flush in relation to one another. The tracks, header seal, and center bearing bracket(s) are designed to be installed on the same plane. Adjustment of end bearing plates will be necessary to keep upper tracks on the same plane as lower tracks. All mounting surfaces **MUST BE** smooth and free of any weld beads or bolt heads etc.
5. Check available DEPTH INTO BUILDING (WTC) and verify that the upper track assembly will fit within the given space. Refer to the track print for required track depth.
6. Check for potential obstructions that may impede the door's normal upward and downward travel such as an electrical box, sprinkler head, pipe etc. If track adjustment or modification is necessary, please contact TKO DOORS for assistance.
7. Check that the floor mounting area is level from right to left side within 1/4". Be prepared to shim under one side of track if necessary.

SITE PREPARATION (continued)

TRACK MOUNTING SURFACE

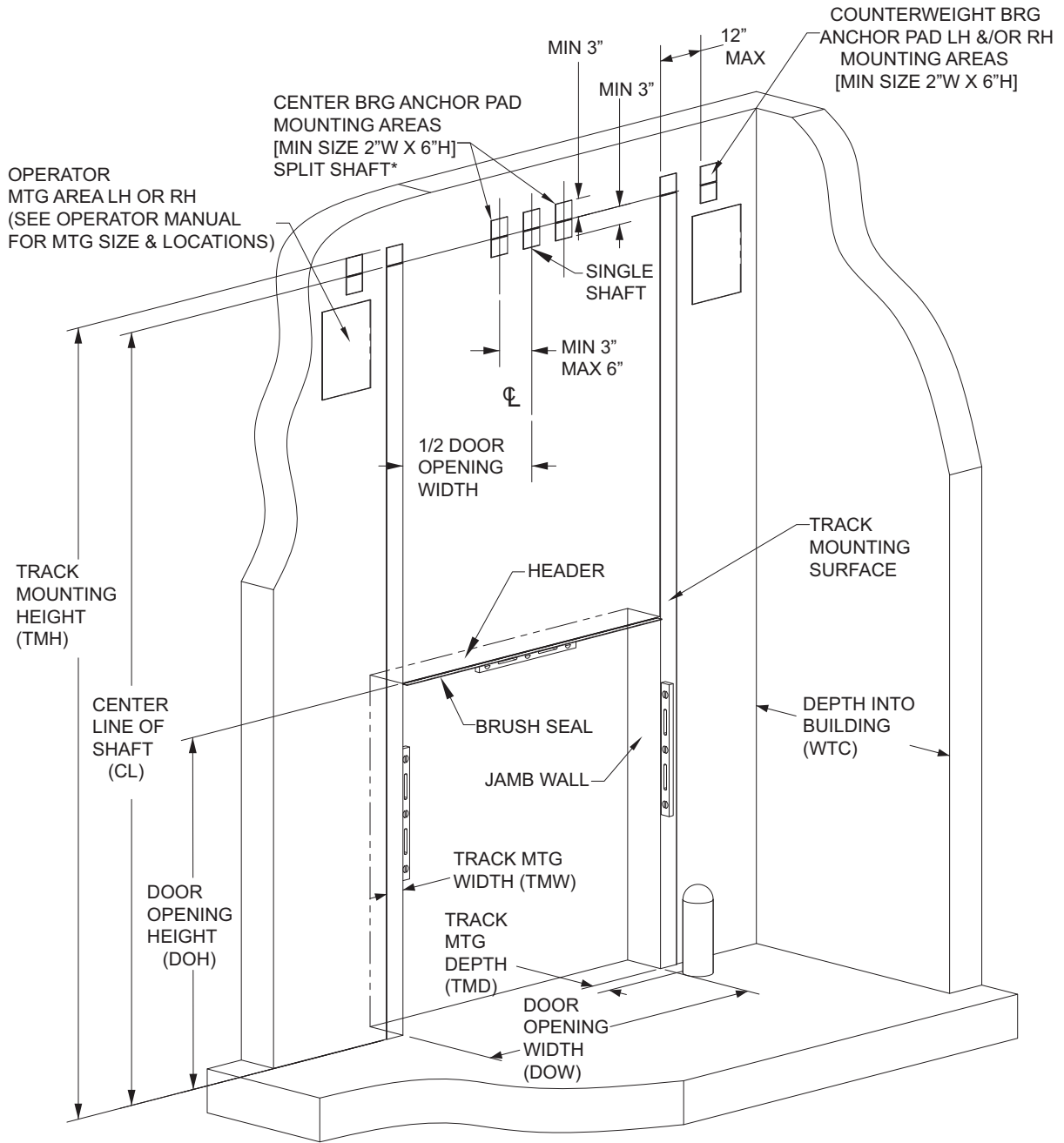

* OR 6" DUAL SPRING SINGLE SHAFT

TRACK ANCHORING APPROVED METHODS

STRUCTURE

1. All anchors/fasteners shall be 3/8" DIA and placed in the second from the bottom anchor hole of the track and then at 18 inch intervals (or every 3rd hole). **Please, refer to the Guide on pg. 11 for specific applications and instructions.**

NOTICE

Welding of tracks is listed as Alternate Anchoring Method, however this method will not allow for any track width adjustments. For this reason TKO recommends the use of self-tapping screws to fasten tracks to metal surfaces instead.

2. Anchors/fasteners MUST BE centered in the slotted track holes to provide the ability to adjust in or out if necessary (an extended bit is recommended).
3. If mounting the track to wood it is not recommended that the tracks be mounted solely to a single 2" x 4", 2" x 6", 2" x etc. wood face jamb. Anchor/fasten through wood jamb and into structural member using a minimum 3/8" x 3" anchor backed with a 3/8" flat washer. Fasteners must be appropriate for the material of the structural member.
4. If mounting the track to steel, position welds or anchors as listed in item 1 above.
5. If mounting the track to solid concrete, anchor tracks using a minimum 3/8" x 1-7/8" concrete sleeve anchor backed with a 3/8" flat washer. If a wood face jamb exists, anchor through wood jamb and into concrete structure. Follow manufacturer's recommendations for installation.
6. If mounting to hollow block, it is important to use 3/8" expansion type anchors specifically designed for this use. Follow manufacturer's recommendations for installation.

⚠ WARNING

Failure to securely position and anchor door tracks per the TRACK SPACING dimension and tolerance (engraved on the door mounted Safety Decal) may allow the tracks to spread and allow the door to fall out of its tracks which could result in death or serious injury.

TRACK ANCHORING APPROVED METHODS (continued)

STEEL TRACK

NOTE: ALL METHODS OF LOWER TRACK ANCHORING REQUIRE THE TRACK SPACING TOLERANCES OF +/- 1/4" ARE NOT EXCEEDED.

RECOMMENDED

MOUNTING TRACK TO C-90 HOLLOW CONCRETE BLOCK

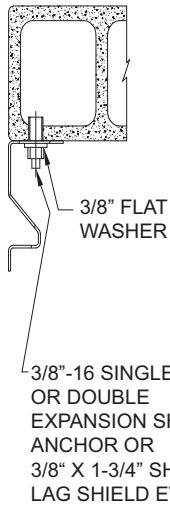

MOUNTING TRACK TO FILLED BLOCK OR SOLID CONCRETE

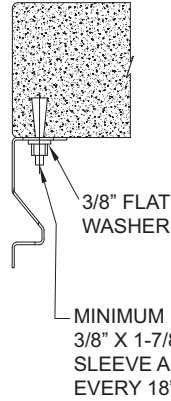

MOUNTING TRACK TO WOOD BACKED BY A SOLID MATERIAL

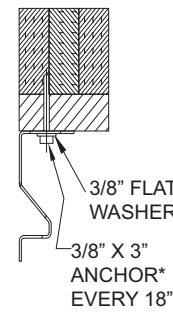

MOUNTING TRACK TO STRUCTURAL STEEL

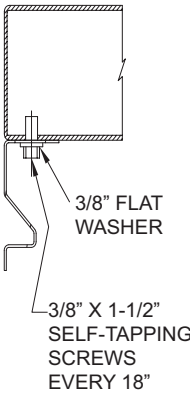

ALTERNATE

MOUNTING TRACK TO STRUCTURAL STEEL WITH FILLET WELDS

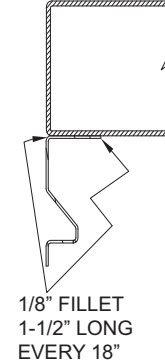

MOUNTING TRACK TO STRUCTURAL STEEL WITH PLUG WELDS

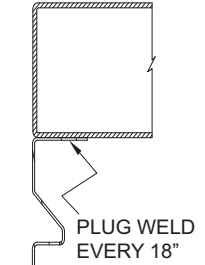

NOTICE:
Alternate Track Mounting Methods will not allow track adjustment if necessary. TKO strongly suggests the use of self-tapping screws instead of welding.

*: TYPE OF ANCHOR USED WILL BE OF SUITABLE LENGTH AND APPROPRIATE FOR TYPE OF SOLID BACKING BEHIND WOOD.

UW TRACK

NOTE: ALL METHODS OF LOWER TRACK ANCHORING REQUIRE THE TRACK SPACING TOLERANCES OF +/- 1/4" ARE NOT EXCEEDED.

RECOMMENDED

MOUNTING TRACK TO C-90 HOLLOW CONCRETE BLOCK

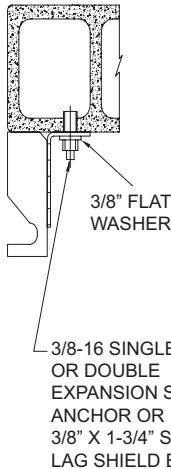

MOUNTING TRACK TO FILLED BLOCK OR SOLID CONCRETE

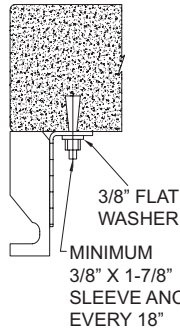

MOUNTING TRACK TO WOOD BACKED BY A SOLID MATERIAL

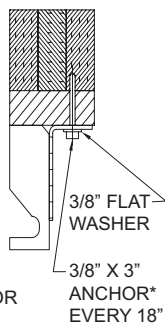

MOUNTING TRACK TO STRUCTURAL STEEL

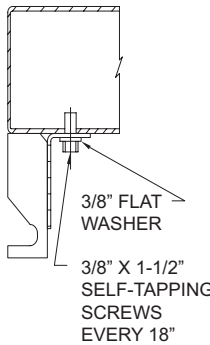

ALTERNATE

MOUNTING TRACK TO STRUCTURAL STEEL WITH FILLET WELDS

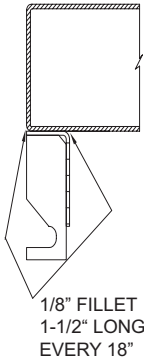

MOUNTING TRACK TO STRUCTURAL STEEL WITH PLUG WELDS

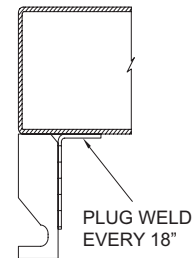

NOTICE:
Alternate Track Mounting Methods will not allow track adjustment if necessary. TKO strongly suggests the use of self-tapping screws instead of welding.

*: TYPE OF ANCHOR USED WILL BE OF SUITABLE LENGTH AND APPROPRIATE FOR TYPE OF SOLID BACKING BEHIND WOOD.

TRACK INSTALLATION

LOWER TRACK INSTALLATION

1. Locate the TRACK PRINT PDS (Production Detail Sheet). It illustrates the assembly of the track component parts.
2. Measure finished jamb opening width. The actual jamb width must match with the panel width inscribed on the door. Call TKO if door width does not match the opening width.
3. Inspect track pieces and line up so that they match job specific track drawing that was supplied with door. If track drawing is missing, call a TKO Doors customer service representative for assistance. Check the floor pad for level. Tops of tracks **MUST BE** level with one another to within 1/4", or door will not operate smoothly. Shimming of tracks off the floor may be necessary.
4. While holding the lower left hand (LH) track against the jamb and flush to the opening, carefully level it. Use approved fastening method (pg.13) on bottom and top holes in track. Anchors/bolts should be placed in the middle of the slotted holes so tracks can be adjusted later if necessary. If track is to be welded in place, lightly tack the bottom and top only. Do not fill fasteners/ welds until you are certain the correct track spacing has been maintained.
5. The track spacing tool can now be used to set the right hand (RH) track. While holding the track against the jamb, place measuring tool (preferred) or measuring tape on floor, then adjust track until tool ends are touching the inside faces of both tracks (see diagram below). Both tracks must be centered in the opening, and spaced an equal distance away from or into the jambs. Fasten track near floor.
6. Move track spacing tool to upper portion of track and repeat procedure described in step 5.
7. Verify TRACK SPACING. Track **MUST BE** kept at proper spacing with both tracks centered in the opening. Remaining fasteners may now be installed at the correct spacing as described on pg.14 and pg.15 and in the methods illustrated on pg.13.
8. Solidify attachments to wall: Once TRACK SPACING is correct, be certain to tighten down all anchors/ bolts and finish all welds that may have been left incomplete to allow for moving of track.
9. Install floor to track brackets (See page16 for complete installation instructions).
10. Panel stacking may be done at this time if door opening needs to be closed up (See installation instructions pgs. 33 through 37).

NOTE: Track spacing tool is intended to be used for all track sections- lower, upper, and radius sections.

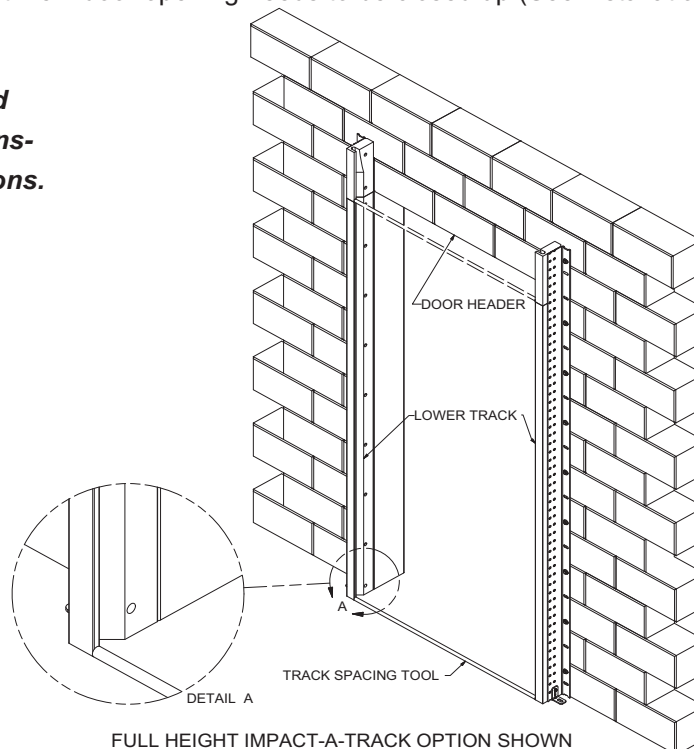

WARNING

Failure to securely position and anchor door tracks per the TRACK SPACING dimension and tolerance (engraved on the door mounted Safety Decal) may allow the door to fallout of its tracks which could result in death or serious injury. Shims may be required between the track and wall surface to ensure the TRACK SPACING is maintained and that the tracks are anchored securely.

TRACK INSTALLATION (continued)

STEEL TRACK

NOTE: ALL METHODS OF LOWER TRACK ANCHORING REQUIRE THE TRACK SPACING TOLERANCES OF +/- 1/4" ARE NOT EXCEEDED.

RECOMMENDED

MOUNTING TRACK TO C-90 HOLLOW CONCRETE BLOCK



MOUNTING TRACK TO FILLED BLOCK OR SOLID CONCRETE

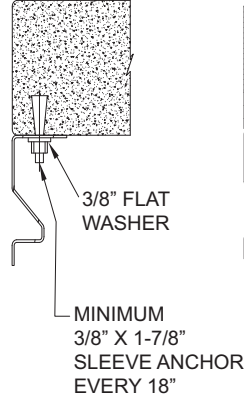

MOUNTING TRACK TO WOOD BACKED BY A SOLID MATERIAL

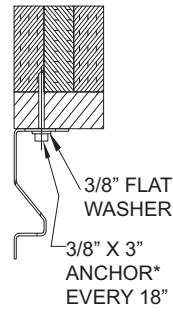

MOUNTING TRACK TO STRUCTURAL STEEL

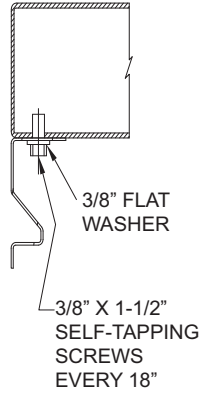

*: TYPE OF ANCHOR USED WILL BE OF SUITABLE LENGTH AND APPROPRIATE FOR TYPE OF SOLID BACKING BEHIND WOOD.

ALTERNATE

MOUNTING TRACK TO STRUCTURAL STEEL WITH FILLET WELDS

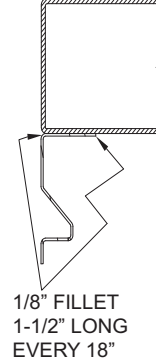

MOUNTING TRACK TO STRUCTURAL STEEL WITH PLUG WELDS

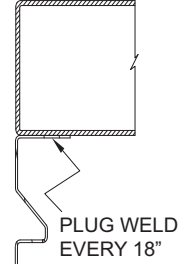

NOTICE:
Alternate Track Mounting Methods will not allow track adjustment if necessary. TKO strongly suggests the use of self-tapping screws instead of welding.

UW TRACK

NOTE: ALL METHODS OF LOWER TRACK ANCHORING REQUIRE THE TRACK SPACING TOLERANCES OF +/- 1/4" ARE NOT EXCEEDED.

RECOMMENDED

MOUNTING TRACK TO C-90 HOLLOW CONCRETE BLOCK



MOUNTING TRACK TO FILLED BLOCK OR SOLID CONCRETE

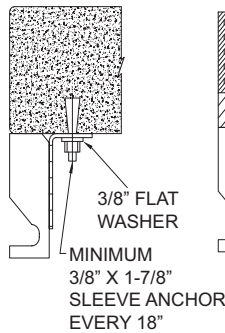

MOUNTING TRACK TO WOOD BACKED BY A SOLID MATERIAL

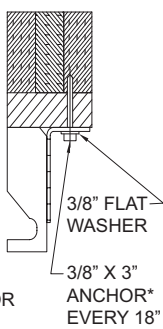

MOUNTING TRACK TO STRUCTURAL STEEL

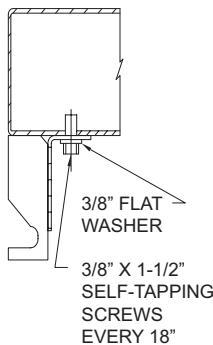

*: TYPE OF ANCHOR USED WILL BE OF SUITABLE LENGTH AND APPROPRIATE FOR TYPE OF SOLID BACKING BEHIND WOOD.

ALTERNATE

MOUNTING TRACK TO STRUCTURAL STEEL WITH FILLET WELDS

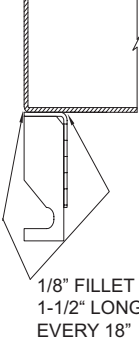

MOUNTING TRACK TO STRUCTURAL STEEL WITH PLUG WELDS

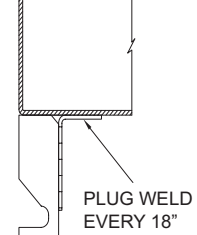

NOTICE:
Alternate Track Mounting Methods will not allow track adjustment if necessary. TKO strongly suggests the use of self-tapping screws instead of welding.

TRACK INSTALLATION (continued)

LOWER TRACK INSTALLATION

STEEL TRACK

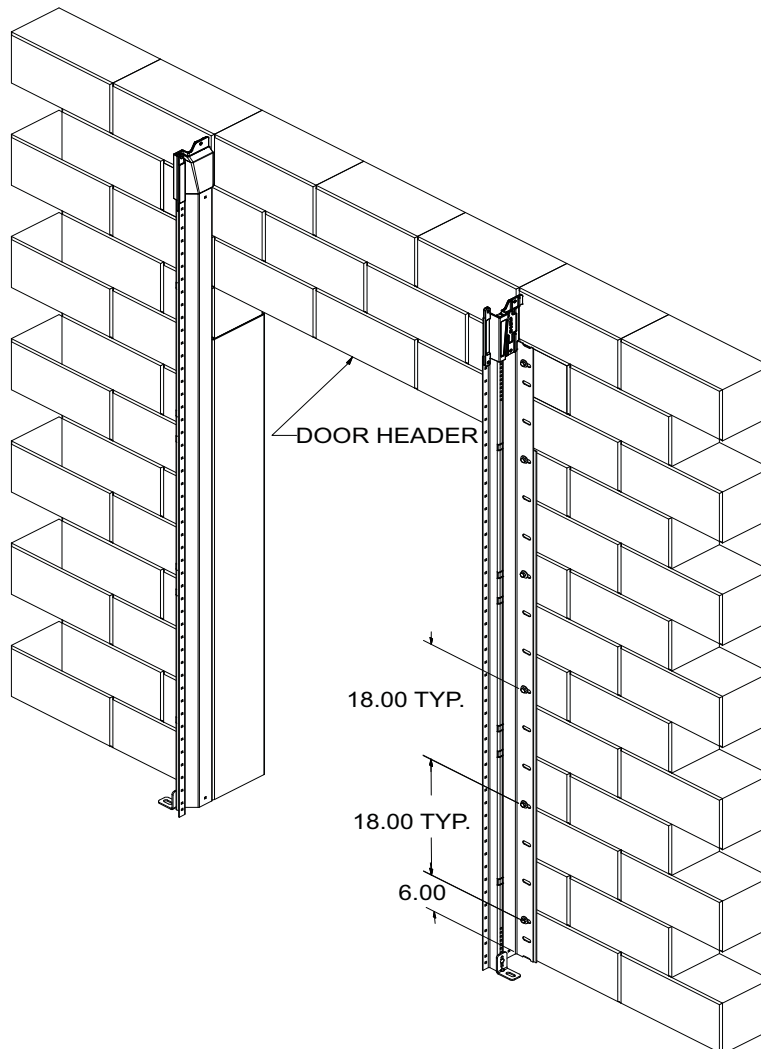
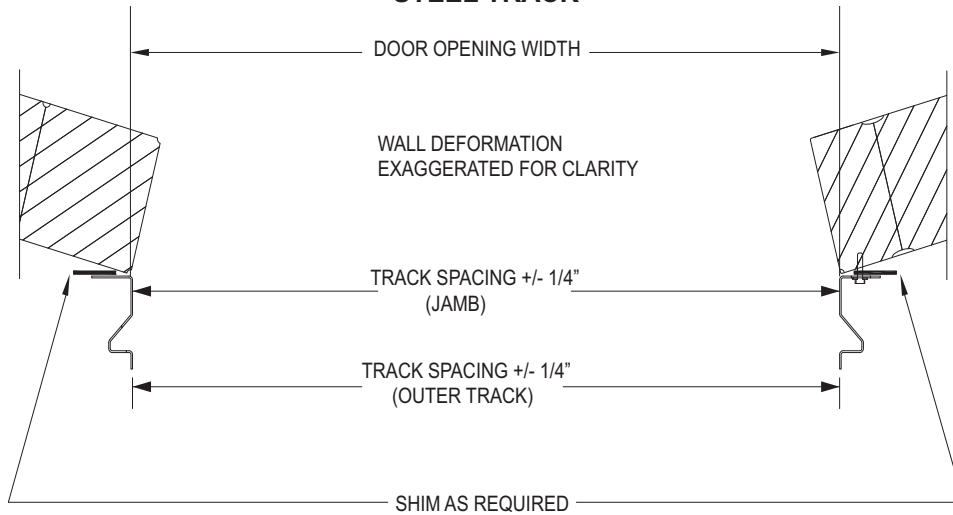

TRACK INSTALLATION (continued)

LOWER TRACK INSTALLATION

UW TRACK

STANDARD MOUNT

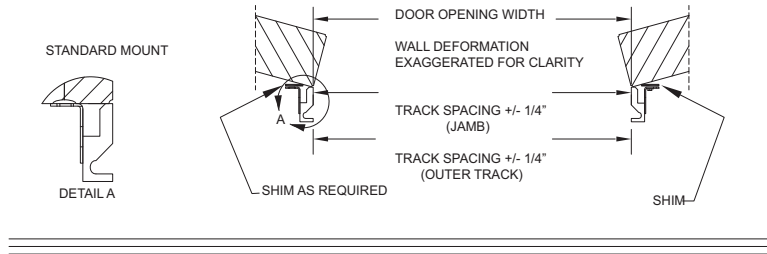

REVERSE MOUNT

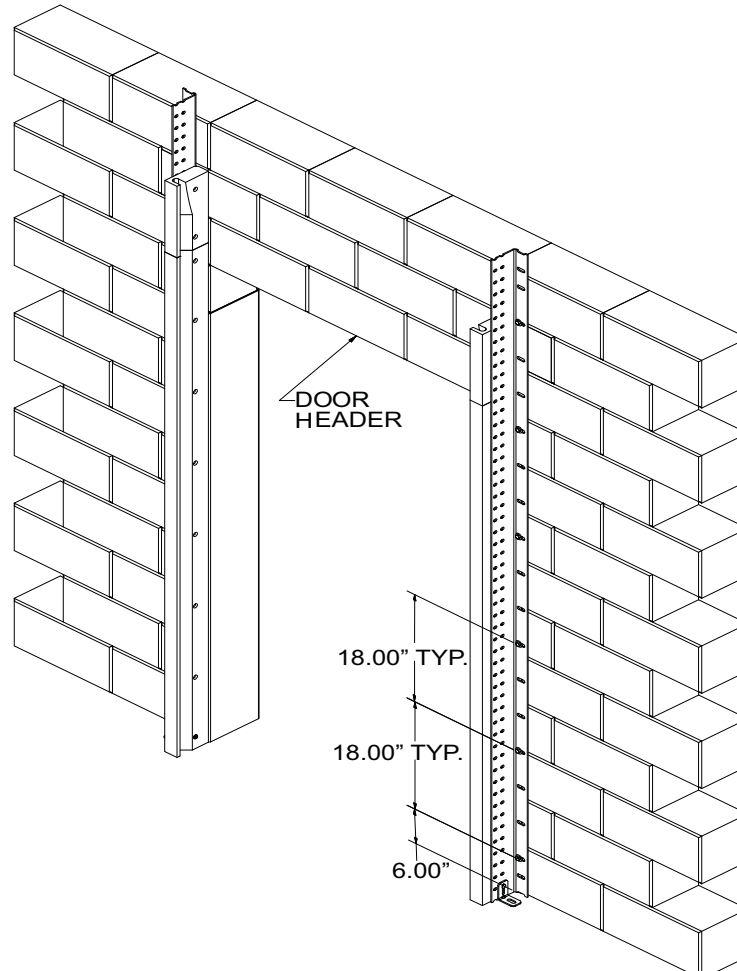
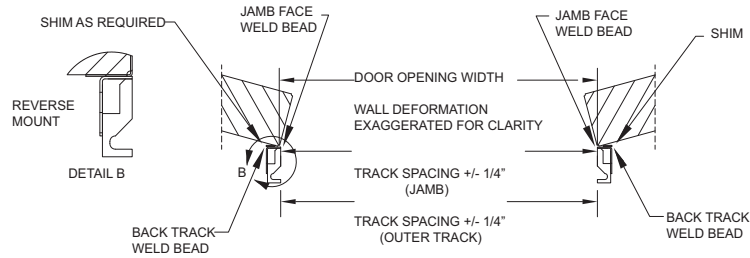

TRACK INSTALLATION (continued)

FLOOR TO TRACK BRACKET INSTALLATION

1. Mount floor to track brackets to both sides of track with the hardware supplied.
2. Check and maintain proper track spacing.
3. Mount brackets to floor with appropriate hardware for floor material (NOT supplied).
4. Proceed to upper track installation: Once lower tracks are securely mounted and spaced, prepare to install upper tracks. See pages 17 through 31 or 34 through 49 (depending on track style) for upper track installation instructions.

FLOOR TO TRACK BRACKET INSTALLATION

ITEM	QTY	PART NO.	DESCRIPTION
1	2	20-00007	BRKT, FLOOR TO TRACK
2	2*	10-00057	SCREW, PFH, 5/16-18 X 3"
3	2*	10-00007	NUT, FLNG, 5/16-18
4	2*	10-00026	BOLT, CRG, 1/4-20 X 3/4"
5	2*	10-00005	NUT, FLNG, 1/4-20

NOTES:

1. MOUNT FLOOR TO TRACK BRACKETS TO BOTTOM SIDE OF TRACK WITH HARDWARE SUPPLIED.
2. CHECK AND MAINTAIN PROPER TRACK SPACING.
3. MOUNT BRACKETS TO FLOOR WITH APPROPRIATE HARDWARE FOR FLOOR MATERIAL (NOT SUPPLIED).

* INCLUDED IN HARDWARE BAG 30-00574-HRDW, FLOOR TO TRACK BRACKET.

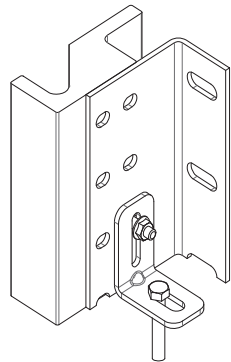

**FULL HEIGHT IMPACT-A-TRACK
(RH SIDE SHOWN)**

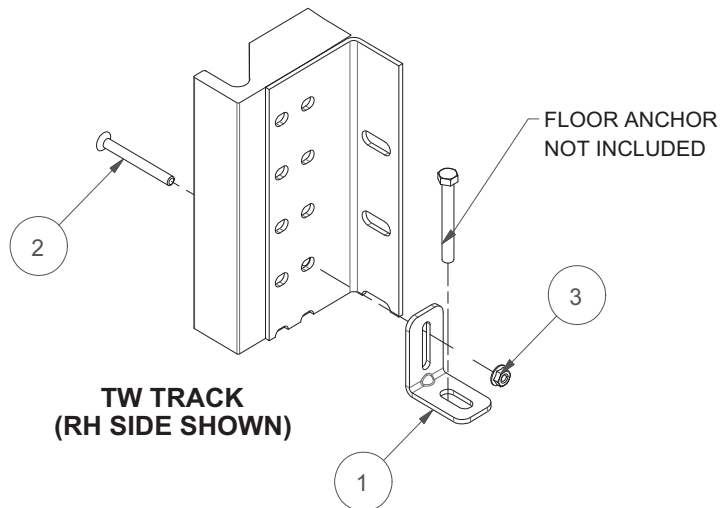

**TW TRACK
(RH SIDE SHOWN)**

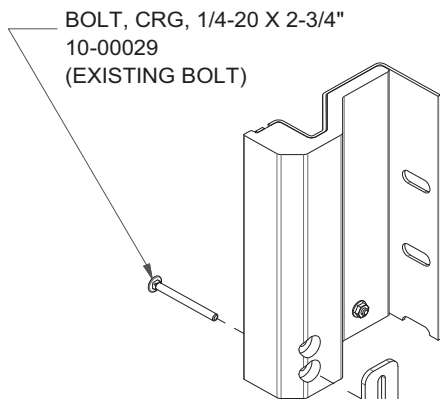

**STEEL TRACK WITH
IMPACT-A-TRACK OPTION
(RH SIDE SHOWN)**

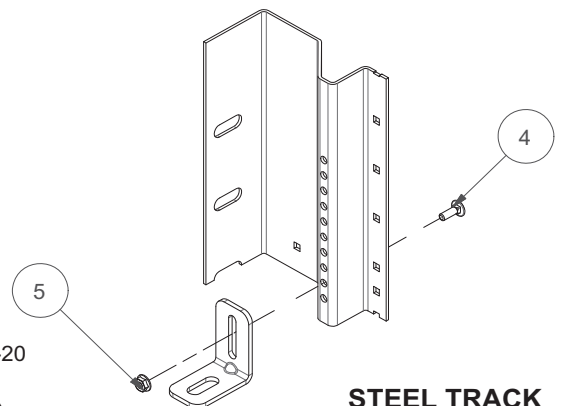

**STEEL TRACK
(LH SIDE SHOWN)**

STEEL TRACK INSTALLATION (continued)

UPPER STEEL TRACK INSTALLATION

The location of the INSTALLATION INSTRUCTIONS for the various UPPER TRACK STYLES are listed in the table below.

TRACK STYLE	INSTALLATION INSTRUCTIONS
Straight Vertical Upper Track Installation	Pages 18 through 19
Tilt T1 Upper Track Installation	Pages 20 through 23
Tilt T2 Upper Track Installation	Pages 24 through 27
Roof Pitch Upper Track Installation	Pages 28 through 29
High-Lift Upper Track Installation	Pages 30 through 31
Center Spring Pad Installation	Pages 32 through 33

⚠ WARNING

All TKO Dock Doors [except Straight Verticals (SV)] require Safety Spreader Bar cross bracing and Safety Cable Assemblies to be installed in the area from the header to the top end of panel travel per the installation instructions on pages 20 to 31. If the Safety Spreader Bars are not installed properly, the Tracks may spread, if impacted, and allow the door to fall. Failure to follow these instructions could result in death or serious injury.

UPPER STEEL TRACK INSTALLATION

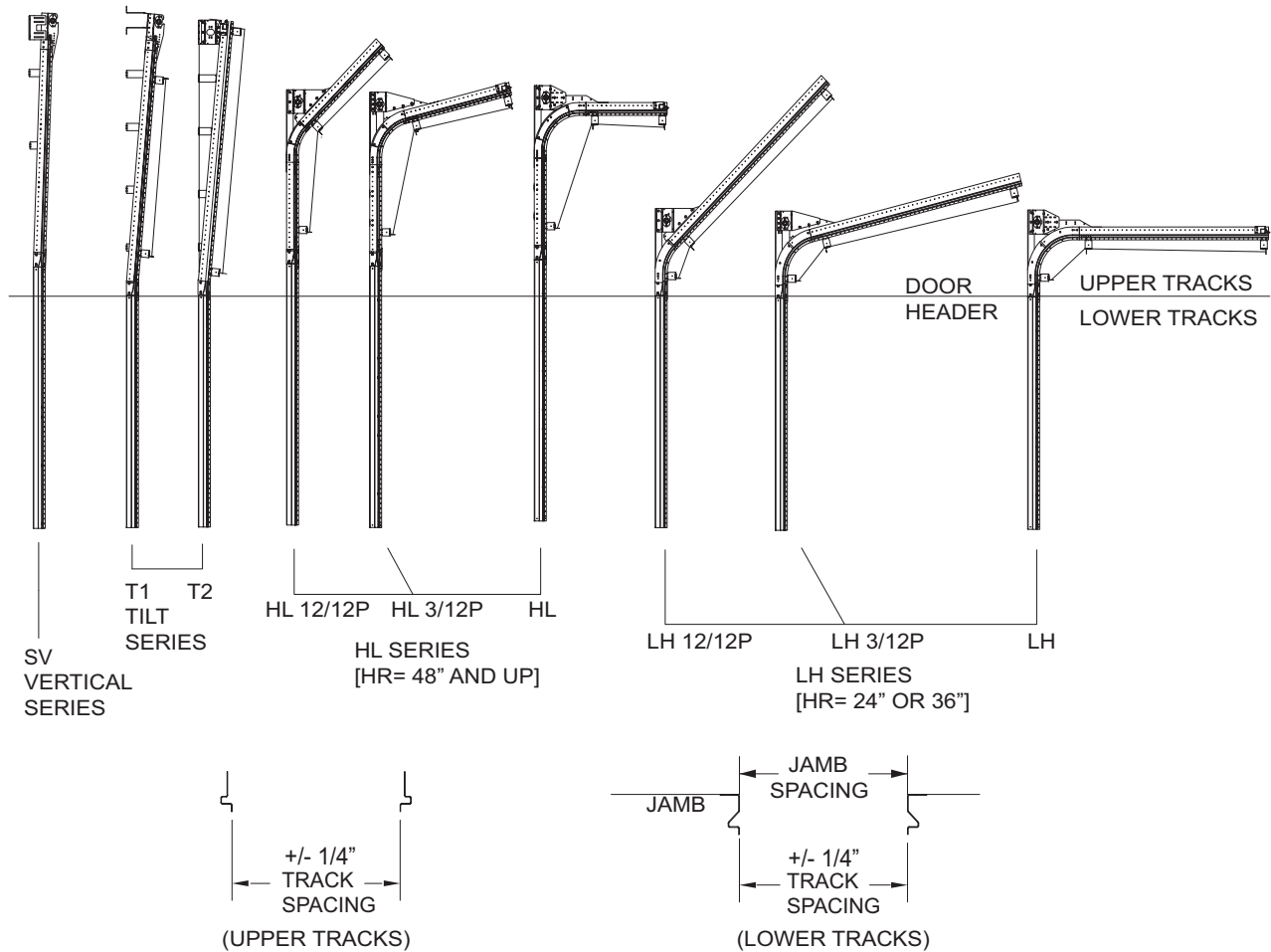

STEEL TRACK INSTALLATION (continued)

STRAIGHT VERTICAL UPPER TRACK INSTALLATION

1. Locate the TRACK PRINT PDS (Production Detail Sheet). It illustrates the assembly of the track component parts.
2. Check how track is assembled: Upper tracks will have 6" cast aluminum transition piece mounted to them, as well as the bearing plates. Size restrictions in shipping may have these separated. See job specific track drawing to determine how parts fit together.
3. Attach upper tracks to lowers: Bolt 6" cast aluminum transition to lower tracks. Attach pieces with 1/4-20x3/4" carriage bolts and flange nuts. Pieces **MUST** fit together to give a smooth transition. Any sharp edges may cause plunger damage.

NOTE: ALL METHODS OF UPPER TRACK ANCHORING REQUIRE THE TRACK SPACING TOLERANCES OF +/- 1/4" ARE NOT EXCEEDED.

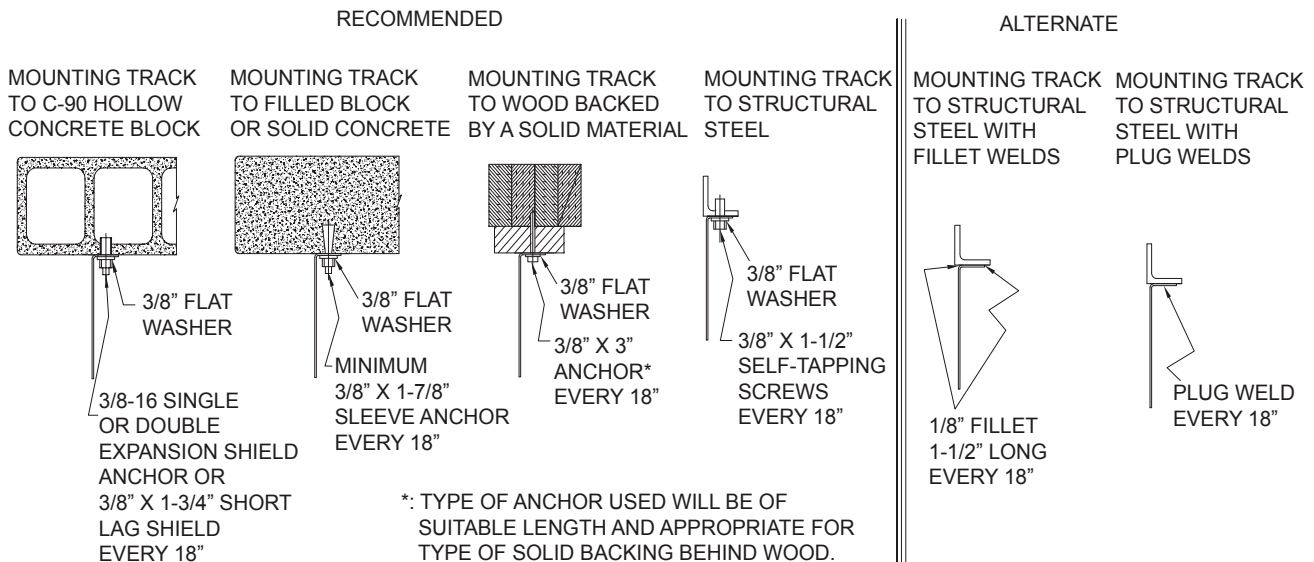

4. Upper tracks will stand off wall at approximately 1 degree angle. Loosen bolts on adjustable upper track bearing bracket then slide bracket back to wall and retighten bolts.
5. Level track and then mount upper track bearing bracket to wall (minimum of 2 anchors) with one of the Recommended Anchoring Methods illustrated above. Follow manufacturer's recommendations for anchor installation.
6. Secure upper track section to wall with provided track mounting brackets (2 per side) with equal spacing (See page 19). Attach track mounting brackets to upper track section with 1/4-20 x 3/4" carriage bolts and flange nuts. Secure track mounting brackets to the wall with one of the Recommended Anchoring Methods illustrated above. Follow manufacturer's recommendations for anchor installation.
7. Repeat steps 4 through 6 for opposite side track. Make sure this track is adjusted to the same distance away from wall. **DO NOT level this side.** Use supplied track spacing tool to set distance. You may also measure over to the opposite track and position it at the track spacing dimension engraved on the Safety Decal located on the 3rd panel of the door. Follow manufacturer's recommendations for anchor installation.

⚠ WARNING

Failure to securely position and anchor door tracks per the TRACK SPACING dimension and tolerance (engraved on the door mounted Safety Decal) may allow the door to fallout of its tracks which could result in death or serious injury.

STEEL TRACK INSTALLATION (continued)

STRAIGHT VERTICAL UPPER TRACK INSTALLATION

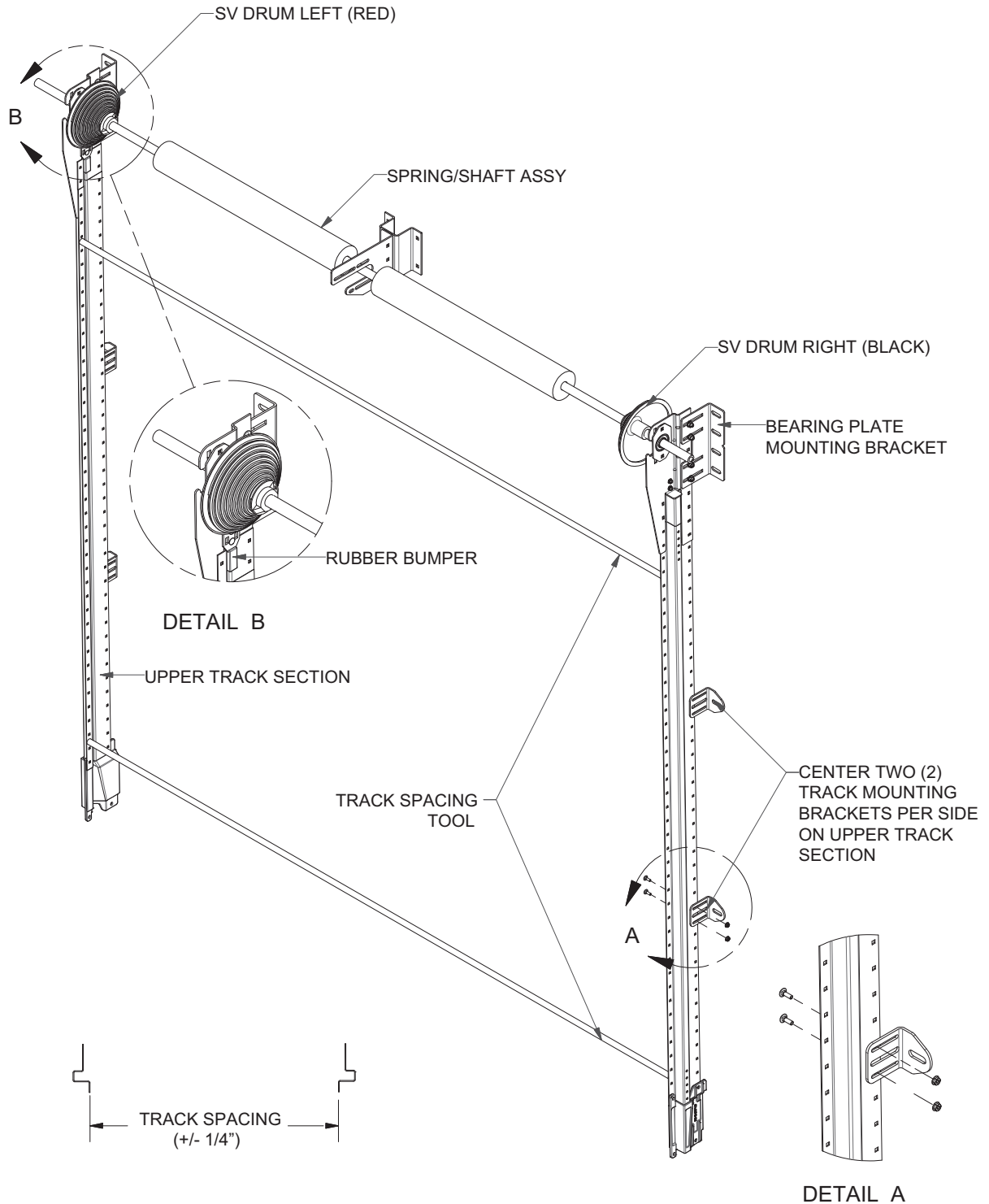

STEEL TRACK INSTALLATION (continued)

TILT T1 UPPER TRACK INSTALLATION

1. Locate the TRACK PRINT PDS (Production Detail Sheet). It illustrates the assembly of the track component parts.
2. Attach upper tracks to lowers: Bolt 6" cast aluminum transition to lower tracks. Attach pieces with 1/4-20x3/4" carriage bolts and flange nuts. Pieces MUST fit together to give a smooth transition. Any sharp edges may cause plunger damage. Track will angle away from wall at approximately a 5° angle (Rise 12", Run 1").

NOTE: ALL METHODS OF UPPER TRACK ANCHORING REQUIRE THE TRACK SPACING TOLERANCES OF +/- 1/4" ARE NOT EXCEEDED.

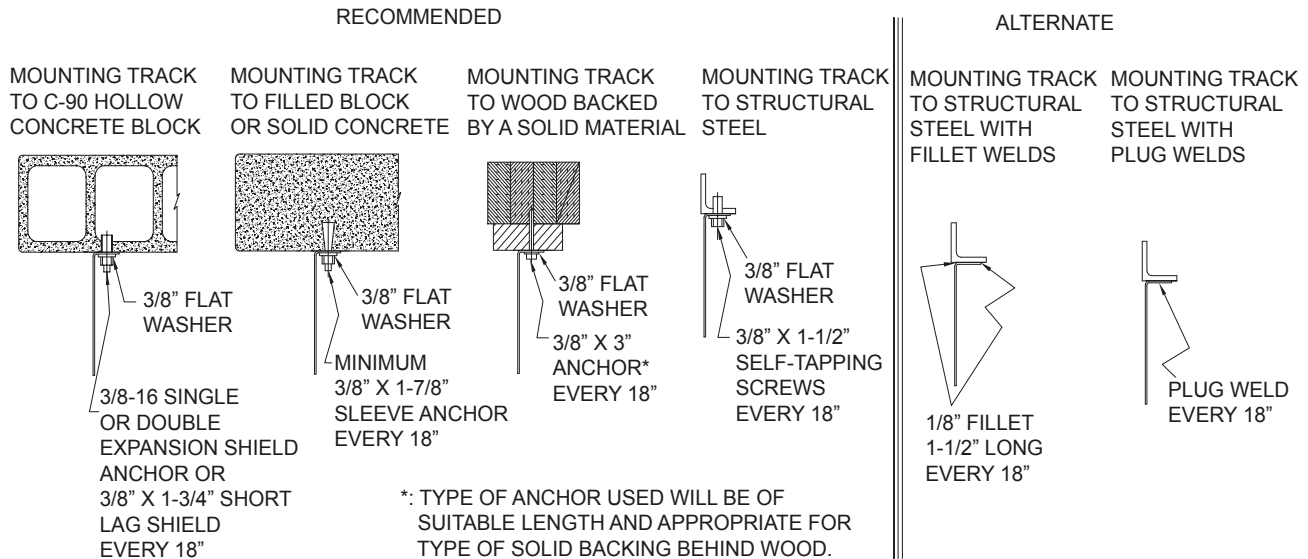

3. Attach top track mounting bracket (normally the longest one provided) to upper track section with 1/4-20 x 3/4" carriage bolts and flange nuts. This bracket should be placed 2" to 6" below end bearing plate (See detail D on page 21). Next, level the track then anchor track mounting bracket to mounting surface using one of the Recommended Anchoring Methods illustrated above. Follow manufacturer's recommendations for anchor installation. Verify the track is level before continuing.

▲ WARNING

Failure to securely position and anchor door tracks per the TRACK SPACING dimension and tolerance (engraved on the door mounted Safety Decal) may allow the door to fall out of the tracks which could result in death or serious injury.

4. Use the track spacing tool to set the opposite track. You may also measure over to the opposite track and position at the track spacing dimension engraved on the Safety Decal located on the 3rd panel of the door. Mark top track mounting bracket anchor location on wall. Secure it using one of the Approved Anchoring Methods illustrated above.

(NOTE: Verify the distance between the mounting surface and the top edge of the track is the same on both sides.)

5. Fill in track mounting brackets (both sides) every 22" to 26" above the door header. (See page 21)
6. Attach C-channel to upper track bearing brackets to run from the backside of one bearing bracket to the other. Attach C-channel to top set of holes on bearing bracket with 3/8-16 x 1" carriage bolts, flange nuts and flat washers. Verify that track spacing is still correct and tracks are level.
7. Attach hardware to C-channel: Attach adjustable angle brackets to top and bottom of C-channel in the center of the assembly with 1/4-20 x 3/4" carriage bolts and flange nuts and anchor onto wall. These prevents C-channel from twisting and stabilizes the upper track (See Detail C, page 21) Mount center spring support to C-channel with 3/8-16 x 1" carriage bolts and flange nuts. Location may vary according to quantity and length of springs.

STEEL TRACK INSTALLATION (continued)

TILT T1 UPPER TRACK INSTALLATION

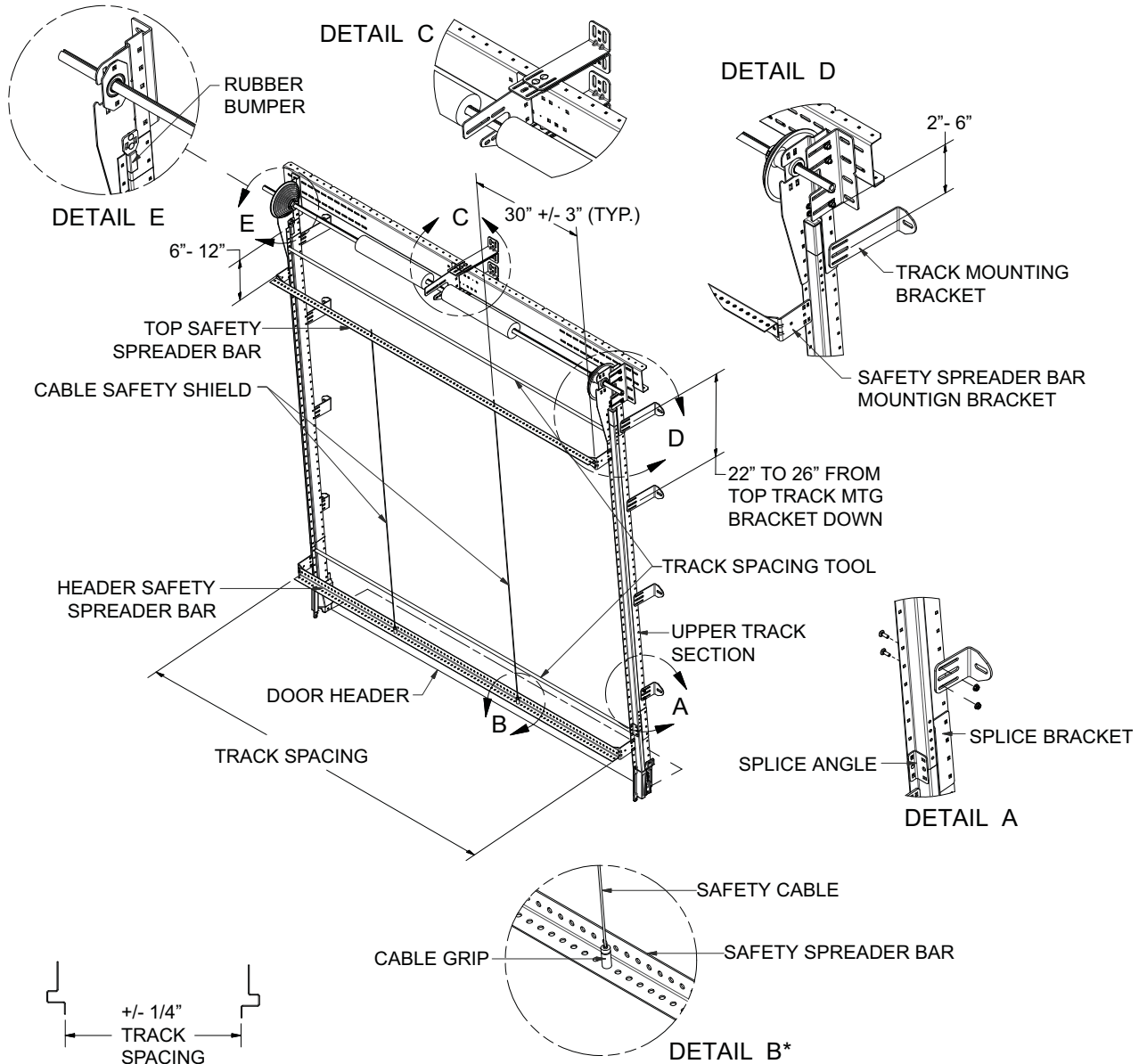

NOTE: TRACK SPACING MUST BE MAINTAINED THROUGHOUT ENTIRE LENGTH OF TRACK.

* SEE PAGES 22 AND 23 FOR INSTRUCTIONS ON SAFETY SPREADER BAR INSTALLATION.

▲ WARNING

Failure to securely position and anchor door tracks per the TRACK SPACING dimension and tolerance (engraved on the door mounted Safety Decal) may allow the door to fall out of its tracks which could result in death or serious injury.

STEEL TRACK INSTALLATION (continued)

TILT T1 UPPER TRACK INSTALLATION (continued)

8. Install safety spreader bar assemblies: Mount upper and lower safety spreader bar brackets to straight track with 1/4-20 x 3/4" carriage bolts and flange nuts. Brackets need to be attached 6" to 12" above header and 6" to 12" below top of tracks. (See page 23) Run two (2) safety spreader bars horizontally from brackets and attach to brackets with 5/16-18 x 3/4" carriage bolts and flange nuts. Repeat for the other side of the door opening.
9. Install two (2) Safety Cables: Bolt two safety cable spool ends to the top horizontal safety spreader bar approximately 30" from each end. Attach two cable grip devices to the bottom safety spreader bar approximately 30" from each end. Feed each cable through the top and bottom cable grip devices and pull tight. Trim excess cable.

WARNING

All TKO Dock Doors [except Straight Verticals (SV)] require Safety Spreader Bar cross bracing and Safety Cable Assemblies to be installed in the area from the header to the top end of panel travel per the installation instructions on pages 20 to 31. If the Safety Spreader Bars are not installed, the Tracks may spread, if impacted, and allow the door to fall. Failure to follow these instructions could result in death or serious injury.

STEEL TRACK INSTALLATION (continued)

TILT T1 SAFETY SPREADER BAR INSTALLATION

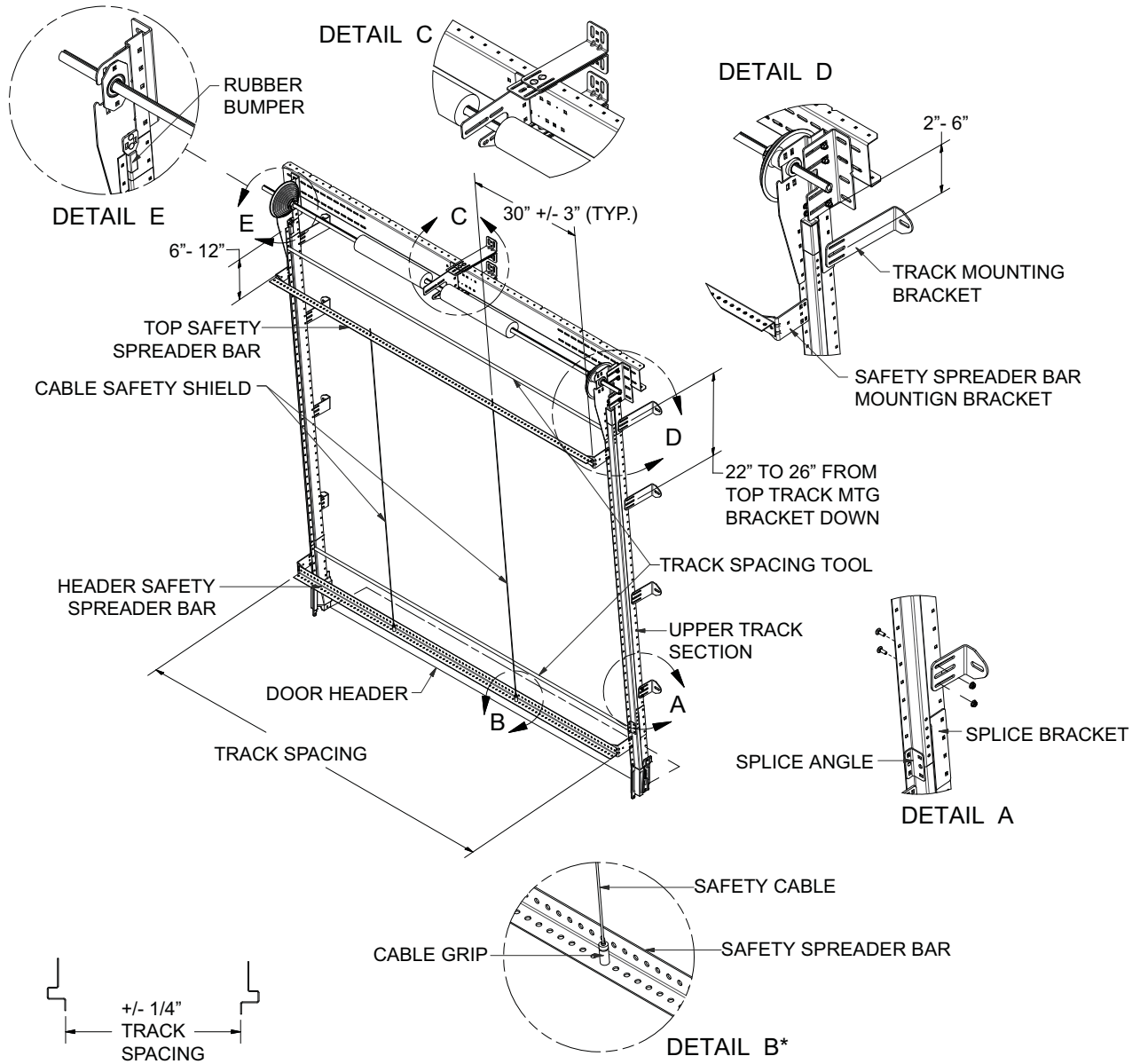

NOTE: TRACK SPACING MUST BE MAINTAINED THROUGHOUT ENTIRE LENGTH OF TRACK.

* SEE PAGES 22 AND 23 FOR INSTRUCTIONS ON SAFETY SPREADER BAR INSTALLATION.

STEEL TRACK INSTALLATION (continued)

TILT T2 UPPER TRACK INSTALLATION

1. Locate the TRACK PRINT PDS (Production Detail Sheet) contained in the Owner's Parts Book. It illustrates the assembly of the track component parts.
2. Attach upper tracks to lowers: Bolt 6" cast aluminum transition to lower tracks. Attach pieces with 1/4-20 x 3/4" carriage bolts and flange nuts. Pieces MUST fit together to give a smooth transition. Any sharp edges may cause plunger damage or cable failure. Track will angle away from wall at approximately a 5° angle. (Rise 12", Run 1")
3. Attach bearing plate to track: Attach bearing plate to bearing spacer bracket at factory established center line (C/L) of shaft with 3/8-16 x 1" carriage bolts and flange nuts (spacer bracket is factory attached to straight track). Level Track then mount End Bearing Plate to the wall (minimum of 2 anchors per plate) with one of the recommended anchoring methods illustrated below. Follow manufacturer's recommendations for anchor installation.
4. Repeat for opposite side, measuring to verify track spacing is correct before securing end bearing plate. Bearing plate MUST BE mounted in the same position as opposite side before tightening bolts.
5. Attach vertical track angle mounting brackets: Attach long leg of track mounting brackets to straight track with 1/4-20 x 3/4" carriage bolts and flange nuts. Fill in track mounting brackets (both sides) every 22" to 26" above the door header. (See page 25)

Mount brackets to the wall with one of the Recommended Anchoring Methods illustrated below. Follow manufacturer's recommendations for anchor installation.

NOTE: ALL METHODS OF UPPER TRACK ANCHORING REQUIRE THE TRACK SPACING TOLERANCES OF +/- 1/4" ARE NOT EXCEEDED.

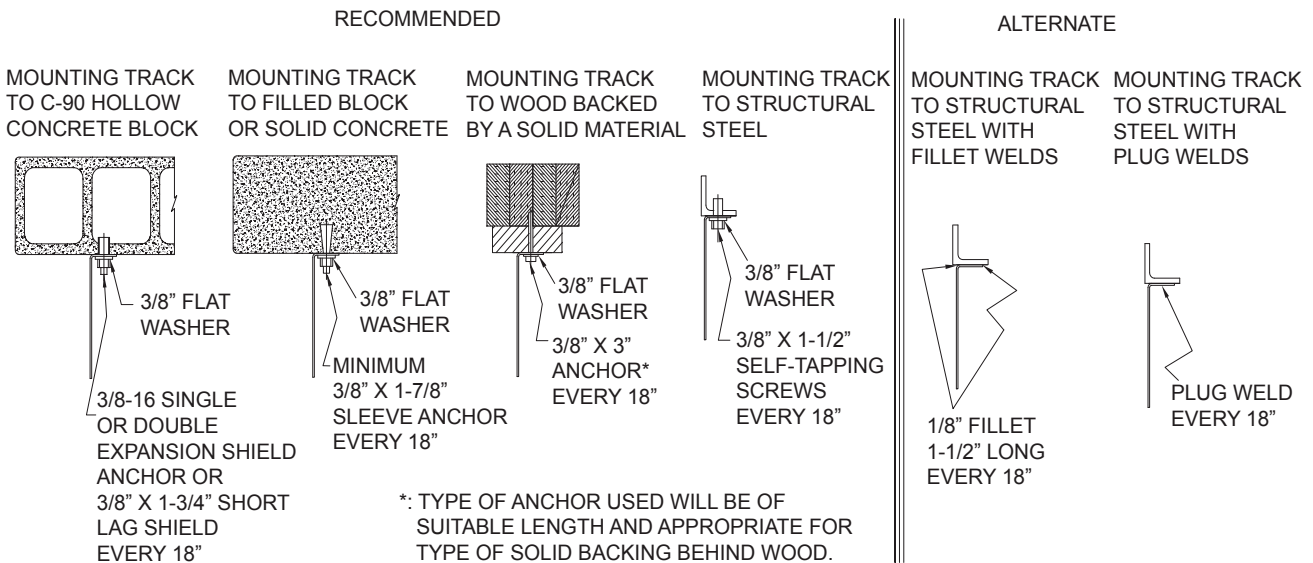

⚠ WARNING

Failure to securely position and anchor door tracks per the TRACK SPACING dimension and tolerance (engraved on the door mounted Safety Decal) may allow the door to fallout of its tracks which could result in death or serious injury.

STEEL TRACK INSTALLATION (continued)

TILT T2 UPPER TRACK INSTALLATION

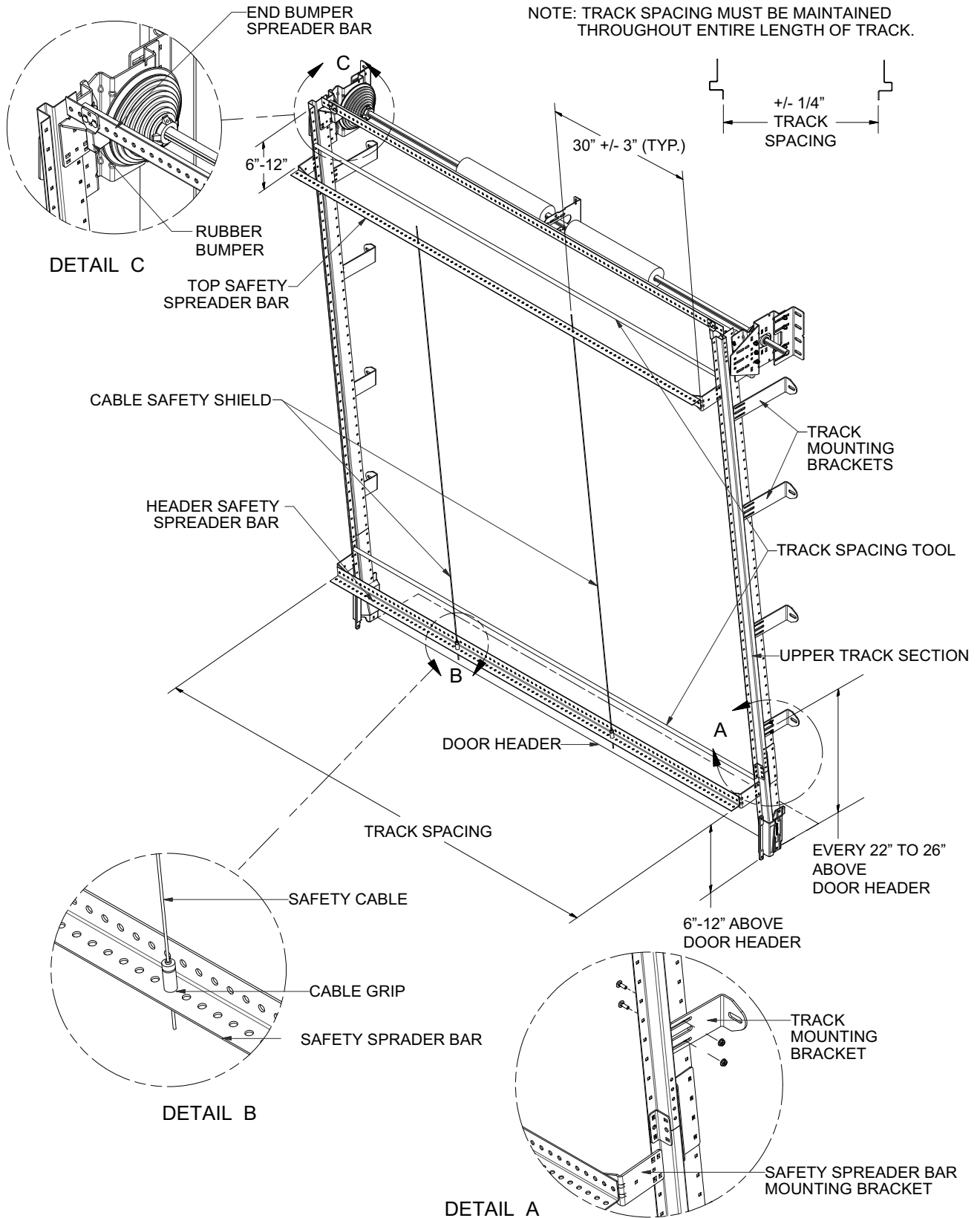

STEEL TRACK INSTALLATION (continued)

TILT T2 UPPER TRACK INSTALLATION (continued)

6. Mount end bumper mounting bar with bumpers: Attach bumper mounting bar brackets at the top of each side of track. (factory attached bolts holding the bearing spacer bracket to track may need to be removed to attach bracket on some track heights). Mount bracket to track using 1/4-20 x 3/4" carriage bolts and flange nuts. Attach bumper mounting bar to the brackets using 5/16-18 x 3/4" carriage bolts and flange nuts. Repeat for both sides. Mount rubber bumpers on the bumper mounting bar on each side of the track, approximately 3" from the inside of the track face.
7. Install safety spreader bar assemblies: Mount upper and lower safety spreader bar brackets to front face of track using 1/4-20 x 3/4" carriage bolts and flange nuts. Brackets need to be placed right above the transition piece at the header header and 6" to 12" below top of tracks. (See page 27) Run two (2) safety spreader bars horizontally from brackets using 5/16-18 x 3/4" carriage bolts and flange nuts. Repeat for the other side of the door opening.
8. Install two (2) Safety Cables: Bolt two safety cable spool ends to the top horizontal safety spreader bar approximately 30" from each end. Attach two cable grip devices to the bottom safety spreader bar approximately 30" from each end. Feed each cable through the top and bottom cable grip devices and pull tight. Trim excess cable.

⚠ WARNING

All TKO Dock Doors [except Straight Verticals (SV)] require Safety Spreader Bar cross bracing and Safety Cable Assemblies to be installed in the area from the header to the top end of panel travel per the installation instructions on pages 20 to 31. If the Safety Spreader Bars are not installed, the Tracks may spread, if impacted, and allow the door to fall. Failure to follow these instructions could result in death or serious injury.

STEEL TRACK INSTALLATION (continued)

TILT T2 SAFETY SPREADER BAR INSTALLATION

NOTE: TRACK SPACING MUST BE MAINTAINED THROUGHOUT ENTIRE LENGTH OF TRACK.

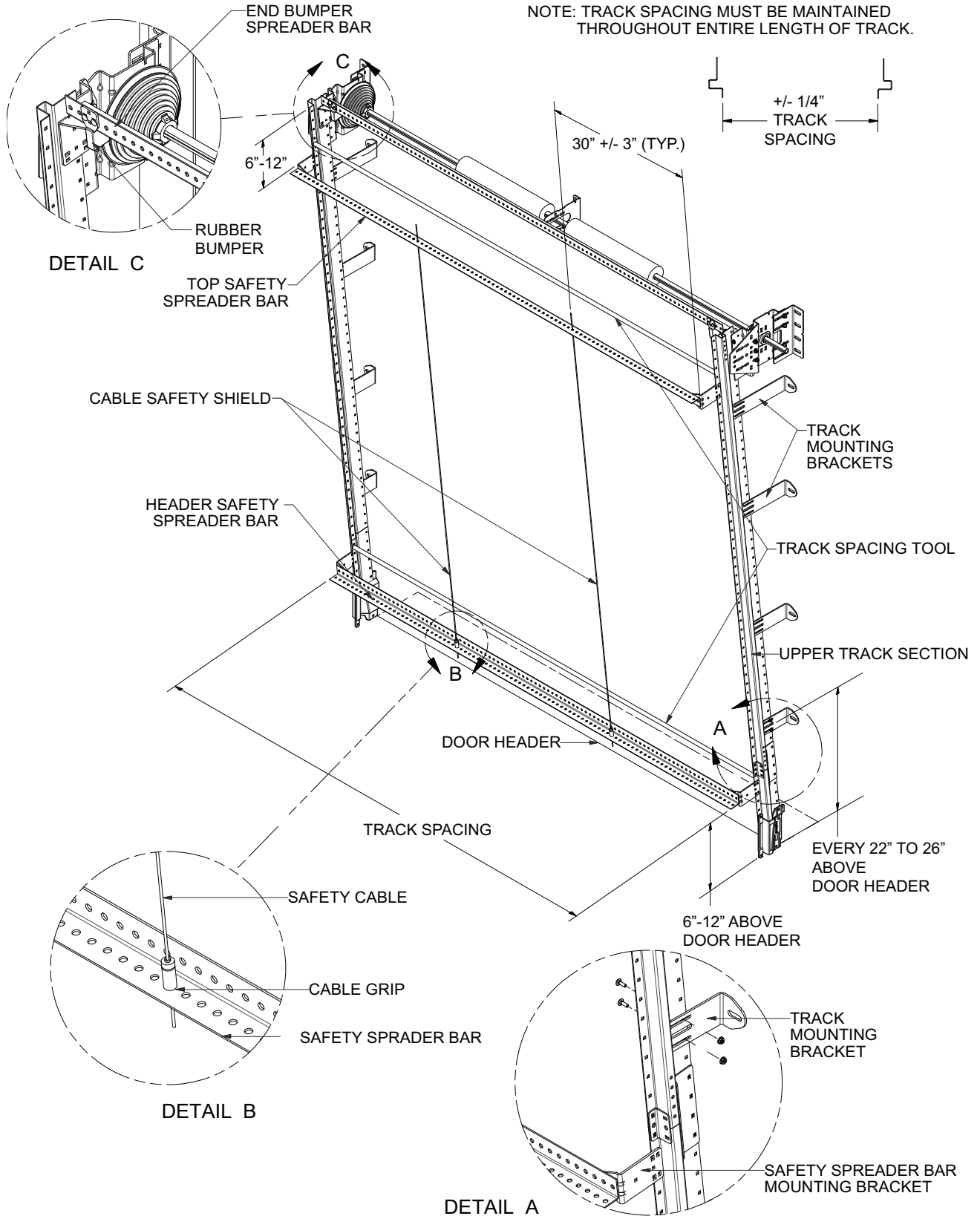

STEEL TRACK INSTALLATION (continued)

ROOF PITCH UPPER TRACK INSTALLATION

1. Locate the TRACK PRINT PDS (Production Detail Sheet) contained in the Owner's Parts Book. It illustrates the assembly of the track component parts.
2. Identify upper supports: Identify a beam or structure to attach the end of the horizontal tracks. You will need to run back-hangs and sway bracing from this structure to the ends of the horizontal tracks once they are up. DO NOT use safety spreader angle for this purpose.
3. Attach upper tracks to lowers: Bolt 6" cast aluminum transition to lower tracks. Attach pieces with 1/4-20 x 3/4" carriage bolts and flange nuts. Pieces MUST fit together to give a smooth transition. Any sharp edges may cause plunger damage or cable failure. Low headroom tracks have transition factory mounted to radius assembly.

NOTE: ALL METHODS OF UPPER TRACK ANCHORING REQUIRE THE TRACK SPACING TOLERANCES OF +/- 1/4" ARE NOT EXCEEDED.

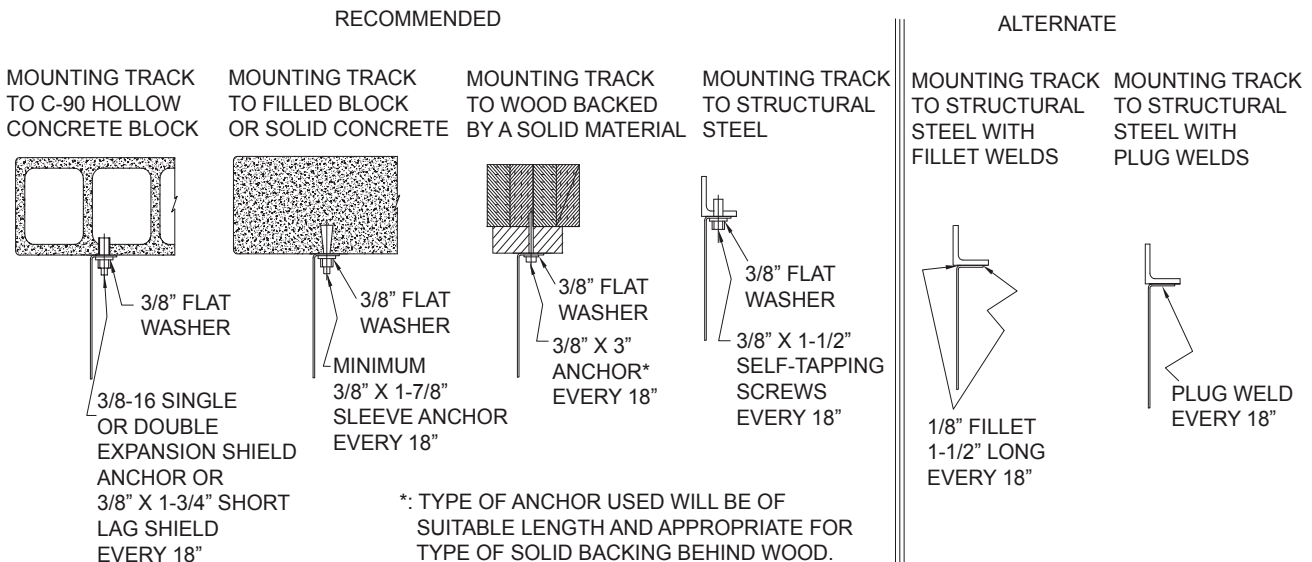

4. Mount horizontal track: Horizontal tracks are factory attached to the radius. Using proper lifting techniques, have helper hold up horizontal track assembly while mounting radius to vertical track. Secure radius to vertical tracks with track splice angle. Pieces MUST fit together to give a smooth transition. Any sharp edges may cause plunger damage or cable failure. Attach with 1/4-20 x 3/4" carriage bolts and flange nuts. Upper track MUST BE plumb and level with lower track. Shimming behind upper track bearing bracket may be necessary. Mount upper track bearing bracket to wall (minimum of 2 anchors per angle) with chosen method. Follow manufacturer's recommendations for anchor installation.
5. Repeat for the opposite side.
IMPORTANT: Measure and place this track at the dimension engraved on the door mounted Safety Decal!
6. Secure upper track sections to wall with 3" evenly spaced track mounting brackets (2 per side) (see pg. 29). Attach track mounting brackets to track with 1/4-20 x 3/4" carriage bolts and flange nuts. Mount track brackets securely to wall with one of the Recommended Anchoring Methods illustrated above. Follow manufacturer's recommendations for anchor installation.

WARNING

Failure to securely position and anchor door tracks per the TRACK SPACING dimension and tolerance (engraved on the door mounted Safety Decal) may allow the door to fall out of its tracks which could result in death or serious injury.

All TKO Dock Doors [except Straight Verticals (SV)] require Safety Spreader Bar cross bracing and Safety Cable Assemblies to be installed in the area from the header to the top end of panel travel per the installation instructions on pages 20 to 31. If the Spreader Bars are not installed, the Tracks may spread, if impacted, and allow the door to fall. Failure to follow these instructions could result in death or serious injury.

STEEL TRACK INSTALLATION (continued)

ROOF PITCH UPPER TRACK INSTALLATION (continued)

7. Install end bumper mounting bar: Mount end bumper mounting bar assembly above the safety spreader bar assembly, at the location you want the door to stop its travel (normally just after the bottom panel clears the header). Make sure track spacing dimension is correct before tightening bolts. Mount rubber bumpers on the bumper mounting bar on each side of the track, approximately 3" from the inside of the track face (See Detail A on the illustration below).
8. Attach back-hangs: Verify that tracks retain proper spacing. Move tracks to necessary width and tie into structure or ceiling with 12 gauge minimum steel angle/back-hang. Sway bracing **MUST** be installed on back-hang to keep tracks from moving. Make sure tracks are running parallel with door panels before securing back-hangs and sway bracing. Attachment of back-hang material to the surrounding structure must be in compliance with all local and state building codes for the specific location.
9. Install safety spreader bar assemblies: Attach (3) safety spreader bar brackets, 6" to 12" above radius, 6" to 12" from end of horizontal track, and right above the transition piece at the header (See the illustration below). Mount brackets to track using 1/4-20 x 3/4" carriage bolts and flange nuts. Attach a total of 3 spreader bars to the brackets using 5/16-18 x 3/4" carriage bolts and flange nuts. Safety spreader bars should run from one track side to the other to keep track from separating if impacted.
10. Install two (2) Safety Cables: Bolt two safety cable spool ends to the top horizontal safety spreader bar 30" from each end. Attach two cable grip devices to the bottom safety spreader bar aligned with cable grip devices installed on top safety Spreader bar. Wrap each cable over the middle safety spreader bar and fasten with cable tie (See Detail B on the illustration below). Feed each cable through the top and bottom cable grip devices and pull tight. Trim excess wire.

ROOF PITCH UPPER TRACK INSTALLATION

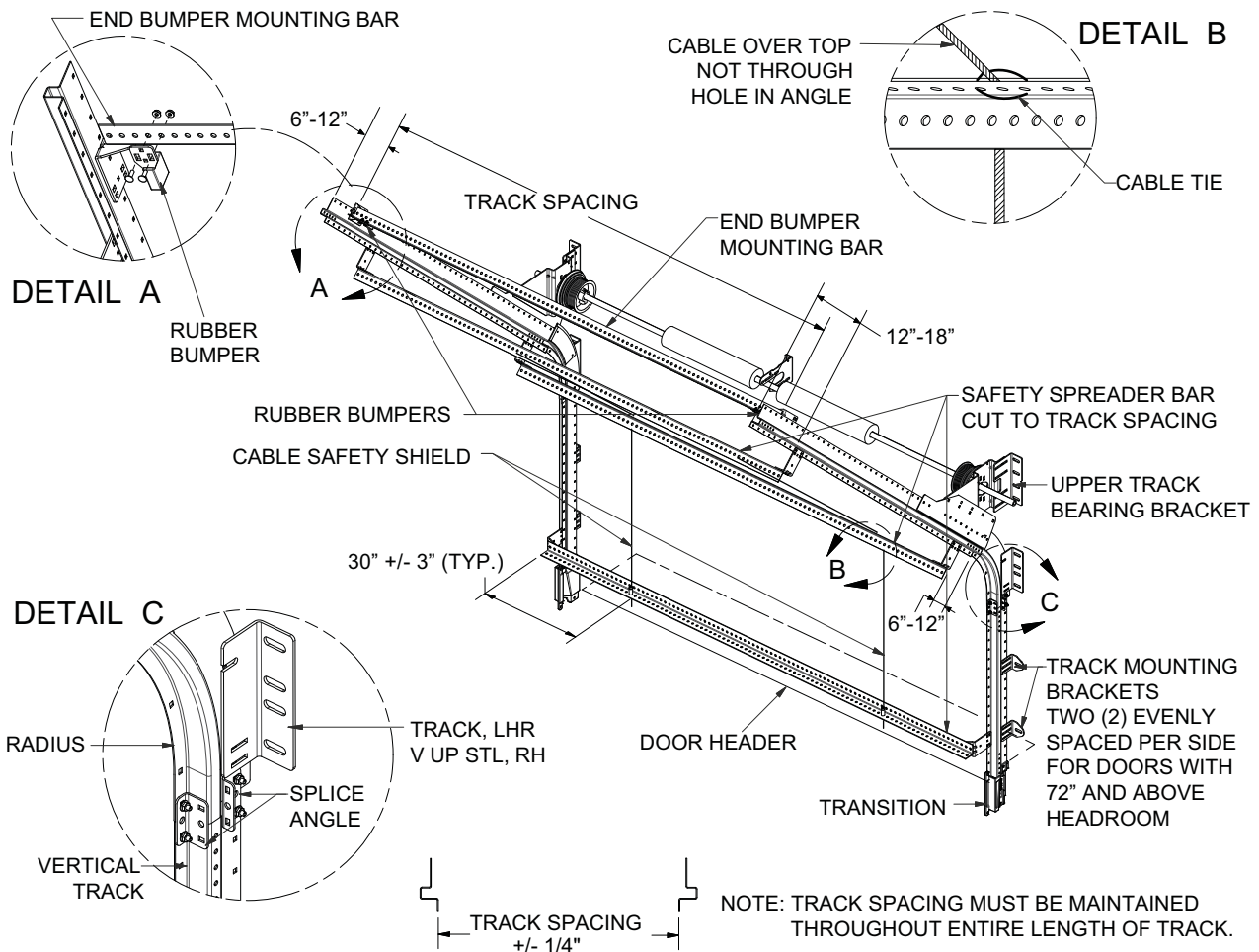

STEEL TRACK INSTALLATION (continued)

HIGH-LIFT UPPER TRACK INSTALLATION

1. Locate the TRACK PRINT PDS (Production Detail Sheet) contained in the Owner's Parts Book. It illustrates the assembly of the track component parts.
2. Identify upper supports: Identify a beam or structure to attach the end of the horizontal tracks. You will need to run back-hangs and sway bracing from this structure to the ends of the horizontal tracks once they are up. DO NOT use safety spreader bar angle for this purpose.
3. Attach upper tracks to lowers: Bolt 6" cast aluminum transition to lower tracks. Attach pieces with 1/4-20 x 3/4" carriage bolts and flange nuts. Pieces MUST fit together to give a smooth transition. Any sharp edges may cause plunger damage or cable failure. Low headroom tracks have transition factory mounted to radius assembly.

NOTE: ALL METHODS OF UPPER TRACK ANCHORING REQUIRE THE TRACK SPACING TOLERANCES OF +/- 1/4" ARE NOT EXCEEDED.

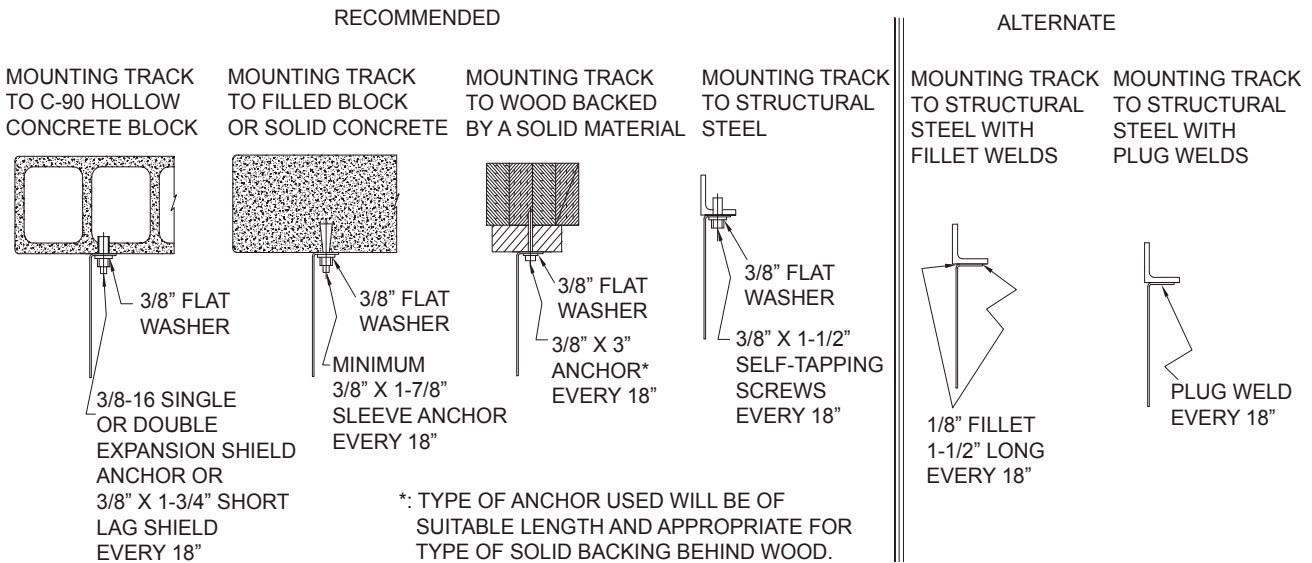

4. Mount horizontal track: Horizontal tracks are factory attached to the radius. Using proper lifting techniques, have helper hold up horizontal track assembly while mounting radius to vertical track. Secure radius to vertical track with track splice angle. Pieces MUST fit together to give a smooth transition. Any sharp edges may cause plunger damage or cable failure. Attach with 1/4-20 x 3/4" carriage bolts and flange nuts. Upper (horizontal) track MUST BE both plumb and level with lower tracks. Shimming behind upper track bearing bracket may be necessary. Mount upper track bearing bracket to wall (minimum of 2 anchors per angle) with chosen method illustrated above. Follow manufacturer's recommendations for anchor installation.
 5. Repeat for the opposite side.
- IMPORTANT: Measure and place this track at the dimension engraved on the door mounted Safety Decal!**
6. Secure upper track sections to wall with 3" evenly spaced track mounting brackets (2 per side) (see pg. 31). Attach track mounting brackets to track with 1/4-20 x 3/4" carriage bolts and flange nuts. Mount track brackets securely to wall with one of the Recommended Anchoring Methods illustrated above. Follow manufacturer's recommendations for anchor installation.

⚠ WARNING

Failure to securely position and anchor door tracks per the TRACK SPACING dimension and tolerance (engraved on the door mounted Safety Decal) may allow the door to fallout of its tracks which could result in death or serious injury.

All TKO Dock Doors [except Straight Verticals (SV)] require Safety Spreader Bar cross bracing and Safety Cable Assemblies to be installed in the area from the header to the top end of panel travel per the installation instructions on pages 20 to 31. If the Safety Spreader Bars are not installed, the Tracks may spread, if impacted, and allow the door to fall. Failure to follow these instructions could result in death or serious injury.

STEEL TRACK INSTALLATION (continued)

HIGH-LIFT UPPER TRACK INSTALLATION (continued)

7. Install end bumper mounting bar: Mount end bumper mounting bar assembly above the safety spreader bar assembly, at the location you want the door to stop its travel (normally just after the bottom panel clears the header). Make sure track spacing dimension is correct before tightening bolts. Mount rubber bumpers on the spreader bar on each side of the track, approximately 3" from the inside of the track face.
8. Attach back-hangs: Verify that tracks retain proper spacing. Move tracks to necessary width and tie into structure or ceiling with 12 gauge minimum steel angle/back-hang. Sway bracing **MUST** be installed on back-hang to keep tracks from moving. Make sure tracks are running parallel with door panels before securing back-hangs and sway bracing. Attachment of back-hang material to the surrounding structure must be in compliance with all local and state building codes for the specific location.
9. Install safety spreader bar assemblies: Attach (3) safety spreader bar brackets, 6" to 12" above radius, 6" to 12" from end of horizontal track, and right above the transition piece at the header (See the illustration below). Mount brackets to track using 1/4-20 x 3/4" carriage bolts and flange nuts. Attach a total of 3 safety spreader bars to the brackets using 5/16-18 x 3/4" carriage bolts and flange nuts. Safety spreader bars should run from one track side to the other to keep track from separating if impacted.
10. Install two (2) Safety Cables: Bolt two safety cable spool ends to the top horizontal safety spreader bar 30" from each end. Attach two cable grip devices to the bottom safety spreader bar aligned with cable grip devices installed on top safety Spreader bar. Wrap each cable over the middle safety spreader bar and fasten with cable tie. Feed each cable through the top and bottom cable grip devices and pull tight. Trim excess wire.

HIGH-LIFT UPPER TRACK INSTALLATION

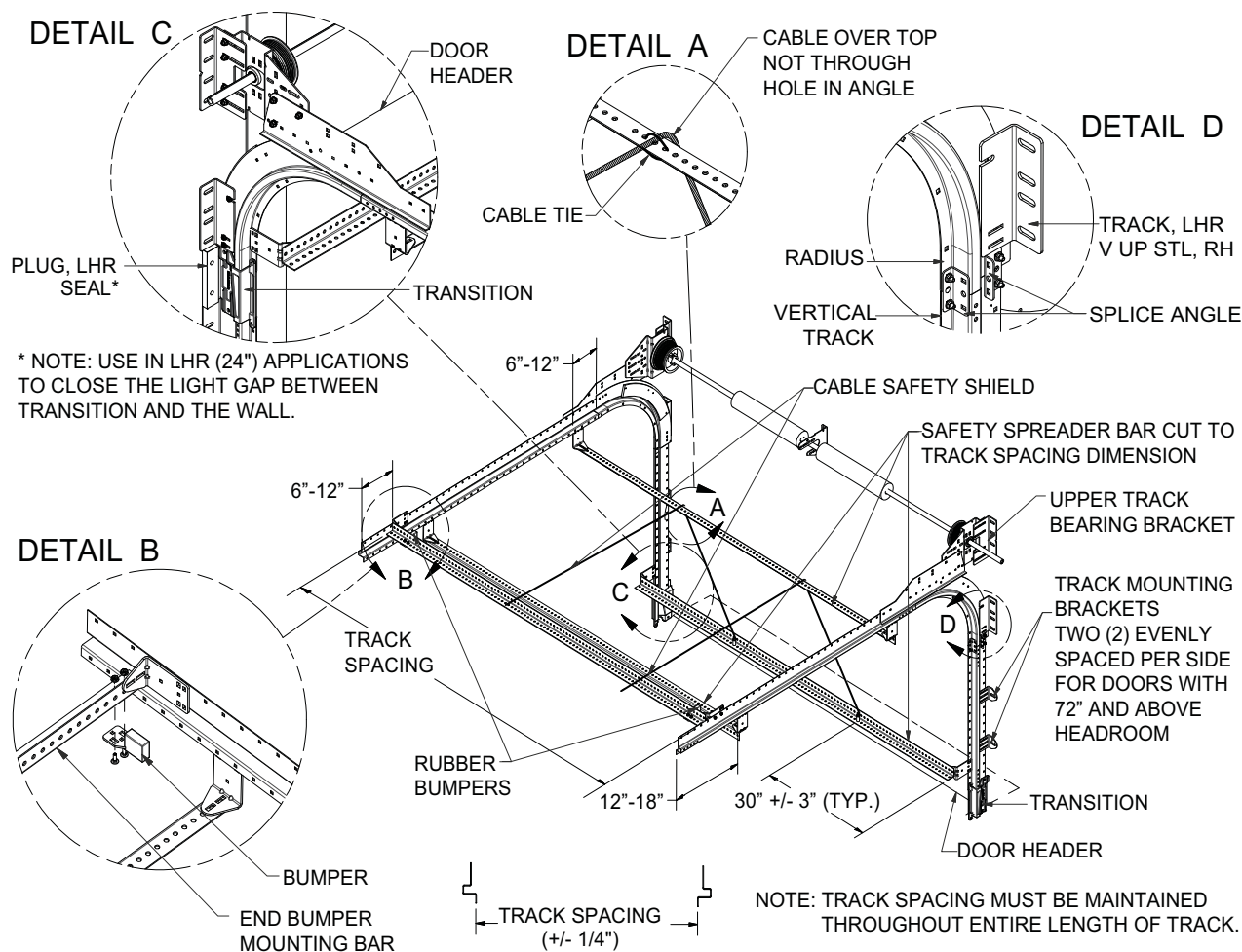

UW TRACK INSTALLATION

UPPER UW TRACK INSTALLATION

The location of the INSTALLATION INSTRUCTIONS for the various UPPER TRACK STYLES are listed in the table below.

TRACK STYLE	INSTALLATION INSTRUCTIONS
Straight Vertical Upper Track Installation	Pages 34 to 35
Tilt T1 Upper Track Installation	Pages 36 to 39
Tilt T2 Upper Track Installation	Pages 40 to 43
Roof Pitch Upper Track Installation	Pages 44 to 45
High-Lift Upper Track Installation	Pages 46 to 47

UW TRACK INSTALLATION (continued)

⚠ WARNING

All TKO Dock Doors [except Straight Verticals (SV)] require Safety Spreader Bar cross bracing and Safety Cable Assemblies to be installed in the area from the header to the top end of panel travel per the installation instructions on pages 32 to 47. If the Safety Spreader Bars are not installed properly, the Tracks may spread, if impacted, and allow the door to fall. Failure to follow these instructions could result in death or serious injury.

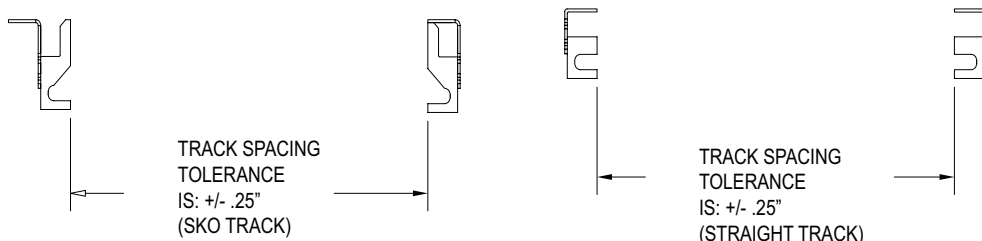
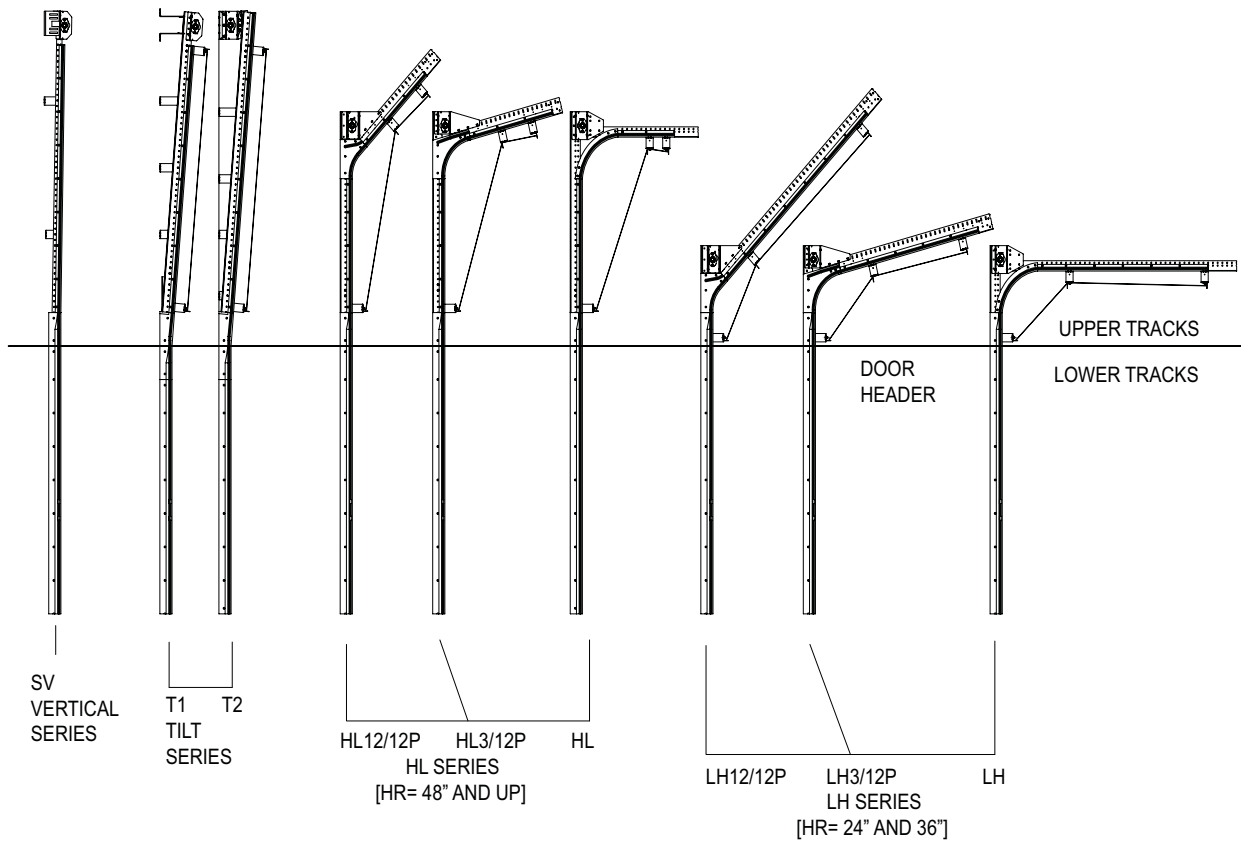

UW TRACK INSTALLATION (continued)

STRAIGHT VERTICAL UPPER TRACK INSTALLATION

1. Locate the TRACK PRINT PDS (Production Detail Sheet) contained in the Owner's Parts Book. It illustrates the assembly of the track component parts.
2. Check how track is assembled: The track will come assembled in one of three ways:
 - A. Lower tracks with extended steel.
 - B. Upper tracks with extended steel.
 - C. Upper and lower tracks have steel and plastic track same length.
Track splice bracket will hold upper and lower tracks together for any combination below.
3. Attach upper tracks to lowers:
 - A. If tracks have extra length of steel on the uppers or lower tracks, bolt protruding portion of either lower or upper plastic track to the extra length of steel angle track on the opposite track assembly (track splice will have to be temporarily removed from lower tracks). Bolt plastic track through steel track to the track splice with flat head, Phillips drive, 5/16-18 x 3" machine screws. Parts must fit together to create a smooth transition. Any sharp edges may cause plunger damage or failure.
 - B. If tracks have plastic and steel the same length, stack track on top of one another to create smooth, level transition and splice together with track splice plate. Bolt plastic track through steel angle track to the track splice with flat head, Phillips drive, 5/16-18 x 3" machine screws.
 - C. Tracks are factory attached to the steel angle with flat head, Phillips drive, 5/16-18 x 2-1/2" machine screws. 3" machine screws are required when bolting through the track splice plated.

NOTE: ALL METHODS OF UPPER TRACK ANCHORING REQUIRE THE TRACK SPACING TOLERANCES OF +/- 1/4" ARE NOT EXCEEDED.

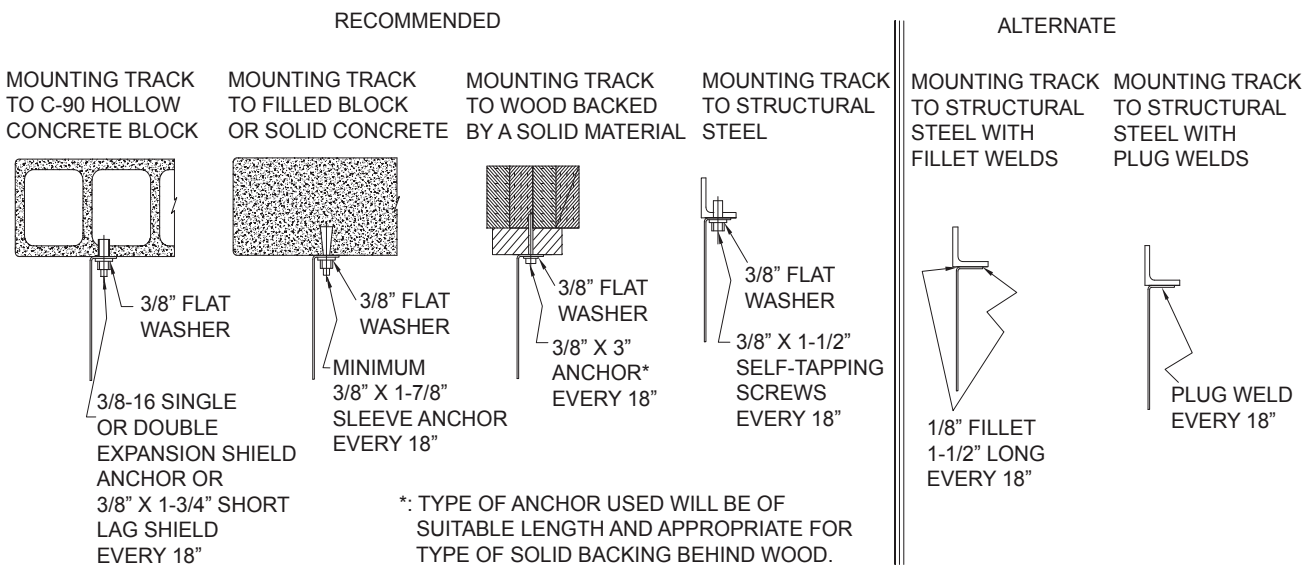

NOTICE

Before mounting End Bearing Plates to wall, level track and also verify upper track is plumb with lower track. Loosen bolts on adjustable bearing plate bracket then slide bracket back to wall. Re-tighten bolts.

4. Level track then mount end bearing plate to the upper track bearing bracket. Mount upper track bearing bracket to wall (minimum of 2 anchors) with one of the Recommended Anchoring Methods illustrated above. Follow manufacturer's recommendations for anchor installation.
5. Secure upper track to wall with 3" jamb brackets (2 per side) to track with equal spacing (See page 35). Attach to track with 1/4-20 x 3/8" carriage bolts and flange nuts. Mount jamb brackets securely to the wall with one of the Recommended Anchoring Methods illustrated above. Follow manufacturer's recommendations for anchor installation.
6. Measure over to the opposite track and position it at the track spacing dimension engraved on the Safety Decal located on the 3rd panel of the door. Repeat steps 4 and 5 above. Follow manufacturer's recommendations for anchor installation.

UW TRACK INSTALLATION (continued)

STRAIGHT VERTICAL UPPER TRACK INSTALLATION

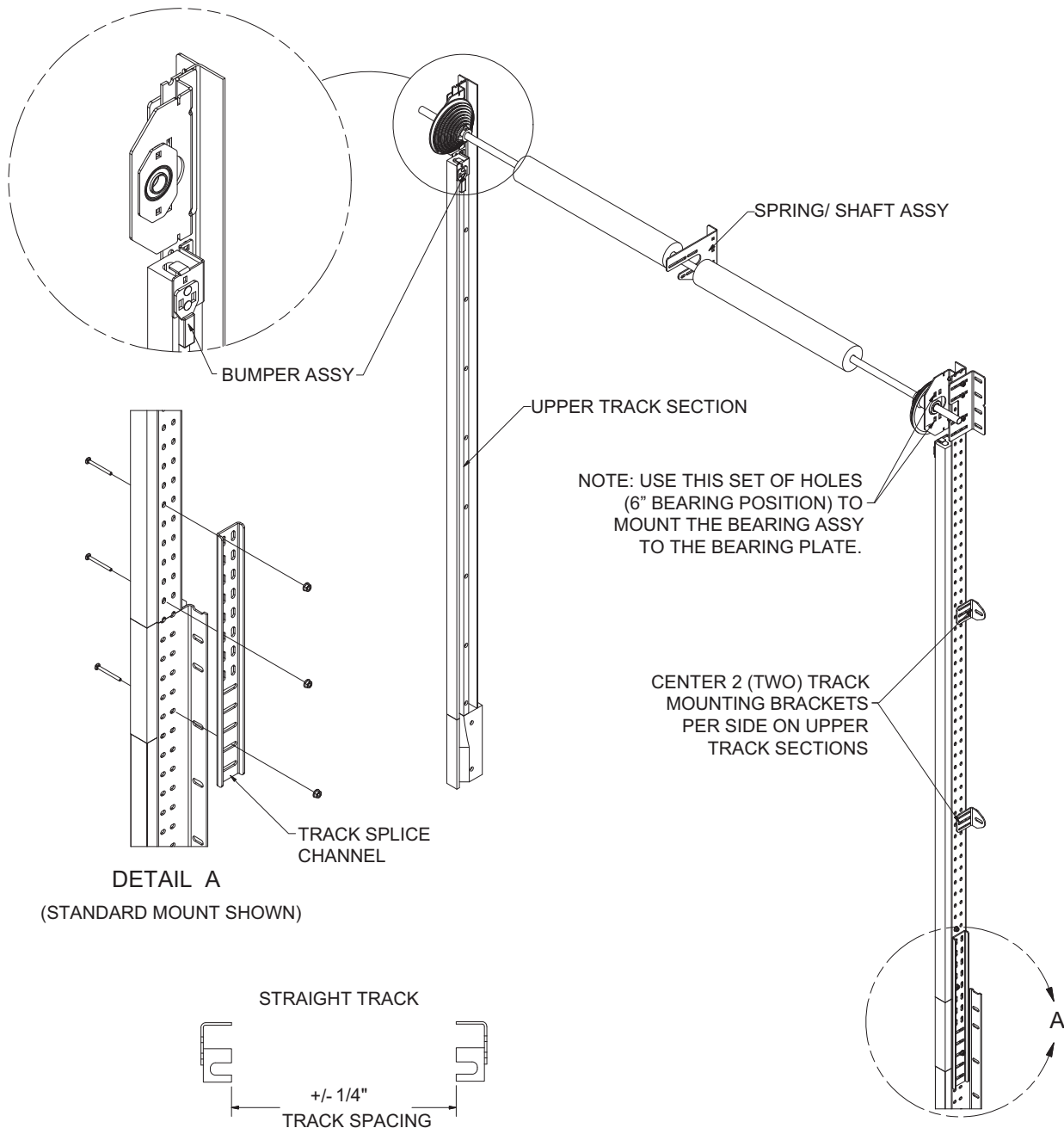

⚠ WARNING

Failure to securely position and anchor door tracks per the TRACK SPACING dimension and tolerance (engraved on the door mounted Safety Decal) may allow the tracks to become too wide and allow the door to fall out of its tracks which could result in death or serious injury. Upper tracks must run straight, level, and plumb with lower tracks.

UW TRACK INSTALLATION (continued)

TILT T1 UPPER TRACK INSTALLATION

1. Locate the TRACK PRINT PDS (Installer Detail Sheet) contained in the Owner's Parts Book. It illustrates the assembly of the track component parts.
2. Stack track on top of one another to create smooth, level transition and splice together with track splice channel. Bolt plastic track through steel angle track to the track splice with flat head, Phillips drive, 5/16-18 x 3" machine screws. Tracks are factory attached to the steel angle with flat head, Phillips drive, 5/16-18 x 2-1/2" machine screws. Pieces MUST fit together to give a smooth transition. Any sharp edges may cause plunger damage or cable failure. Track will angle away from wall at approximately a 5° angle, (Rise 12", Run 1").
3. Attach the Top Track Mounting Bracket within 12" from the highest point of the track. Leave track bolts loose until bracket is anchored to wall.
4. Level this track then anchor the Top Track Mounting Bracket to the building structure using one of the Recommended Anchoring Methods illustrated below. Then tighten bolts at track. Follow manufacturer's recommendations for anchor installation.

NOTE: ALL METHODS OF UPPER TRACK ANCHORING REQUIRE THE TRACK SPACING TOLERANCES OF +/- 1/4" ARE NOT EXCEEDED.

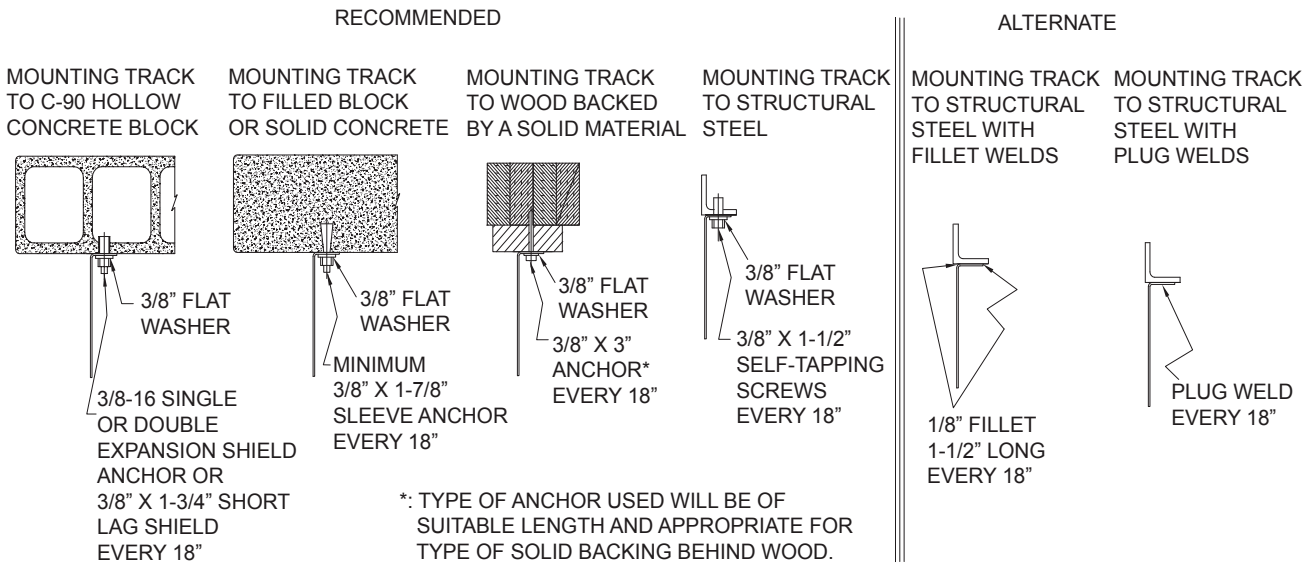

5. Repeat steps 2 through 4 above (except for leveling) for the opposite side. Position the track at the TRACK SPACING dimension engraved on the Serial Number tag that is attached to the third panel of each door. Adjust this track to be the same distance off the wall as the opposite side while maintaining the correct TRACK SPACING dimension.
6. Mount the remaining Track Mounting Brackets every 22" to 26" from top track mounting bracket down (See page 37). Verify the TRACK SPACING dimension and properly torque (23 ft-lb) the fasteners that attach brackets to the track. Tighten the track anchors to the proper torque specified by the anchor manufacturer.
7. Attach C-channel to upper track bearing brackets to run from the backside of one bearing bracket to the other. Attach C-channel to top set of holes on bearing plate with 3/8-16 x 1" carriage bolts, flange nuts and flat washers. Verify that track spacing is still correct and tracks are level.

⚠ WARNING

Failure to securely position and anchor door tracks per the TRACK SPACING dimension and tolerance (engraved on the door mounted Safety Decal) may allow the tracks to become too wide and allow the door to fall out of its tracks which could result in death or serious injury. Shims may be required between the track and wall surface. Tracks must be mounted straight, level, and on the same plane as lower tracks.

UW TRACK INSTALLATION (continued)

TILT T1 UPPER TRACK INSTALLATION

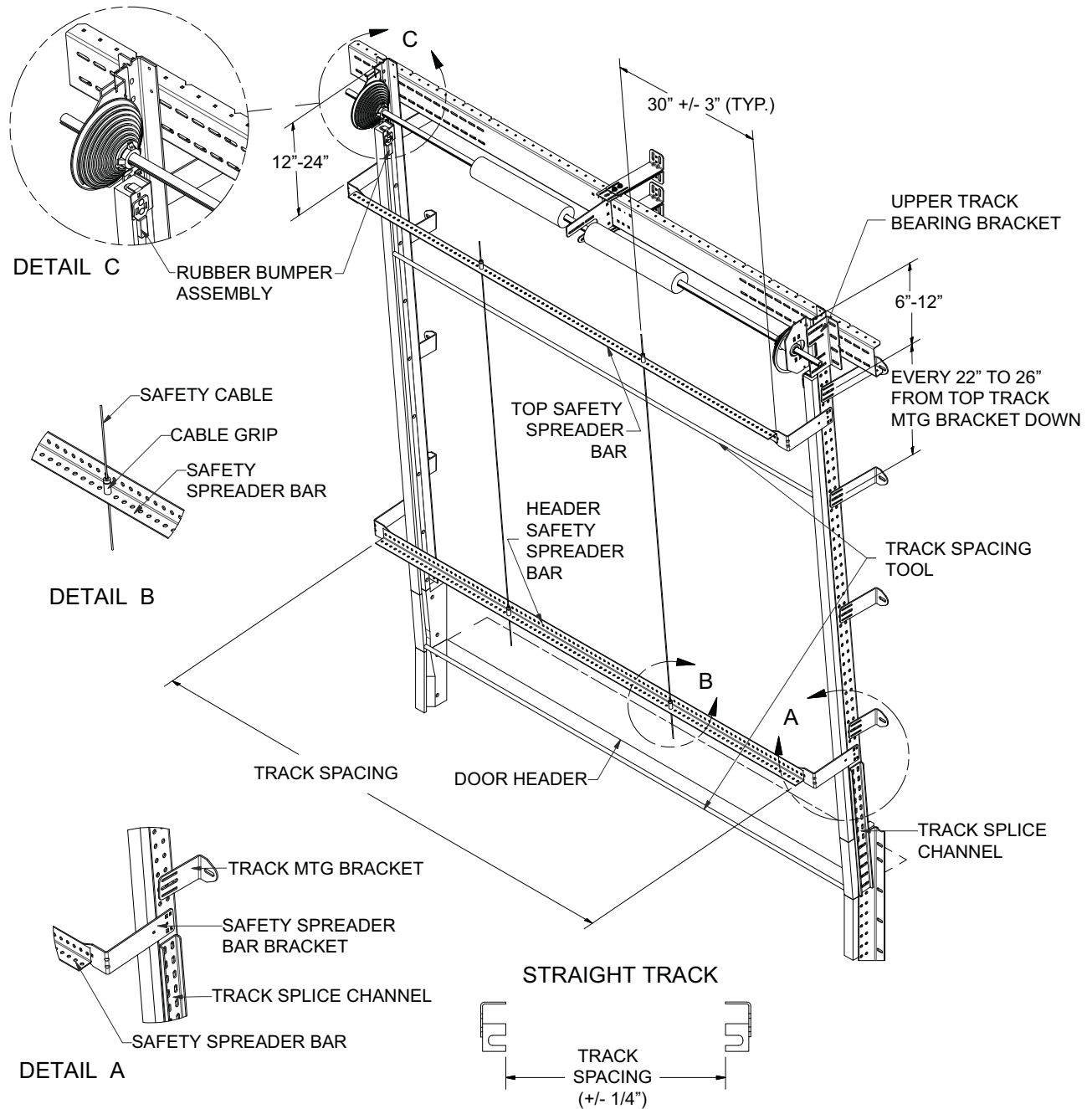

⚠ WARNING

Failure to securely position and anchor door tracks per the TRACK SPACING dimension and tolerance (engraved on the door mounted Safety Decal) may allow the tracks to become too wide and allow the door to fall out of its tracks which could result in death or serious injury. Shims may be required between the track and wall surface to ensure the TRACK SPACING is maintained and that the tracks are anchored securely.

UW TRACK INSTALLATION (continued)

TILT T1 UPPER TRACK INSTALLATION (continued)

8. Attach hardware to C-channel: Attach adjustable angle brackets to top and bottom of C-channel in the center of the assembly with 3/8-16 x 1" carriage bolts and flange nuts and anchor onto wall. These keep tracks from swaying side to side. Mount center spring support to C-channel with 3/8-16 x 1" carriage bolts and flange nuts. Location may vary according to quantity and length of springs.
9. Install Safety Spreader Bar assembly: Mount spreader bar brackets to straight track with 5/16-18 x 3/4" carriage bolts and flange nuts. Brackets need to be attached right above the track splice channel at the header and 12" to 24" below the top of tracks (See page 39).
Mount two (2) spreader bars horizontally from brackets and attach to brackets with 5/16-18 x 3/4" carriage bolts and flange nuts. Repeat for both sides.
10. Install two (2) Safety Cables: Bolt two (2) safety cable spool ends to the top horizontal safety spreader bar approximately 30" from each end. Attach two (2) cable grip devices to bottom safety spreader bar approximately 30" from each end. Feed cable through the cable grip devices and pull tight. Trim excess wire.

▲ WARNING

All TKO Dock Doors [except Straight Verticals (SV)] require Safety Spreader Bar cross bracing and Safety Cable Assemblies to be installed in the area from the header to the top end of panel travel per the installation instructions. If the Safety Spreader Bars are not installed properly, the Tracks may spread, if impacted, and allow the door to fall. Failure to follow these instructions could result in death or serious injury.

UW TRACK INSTALLATION (continued)

TILT T1 UPPER TRACK INSTALLATION

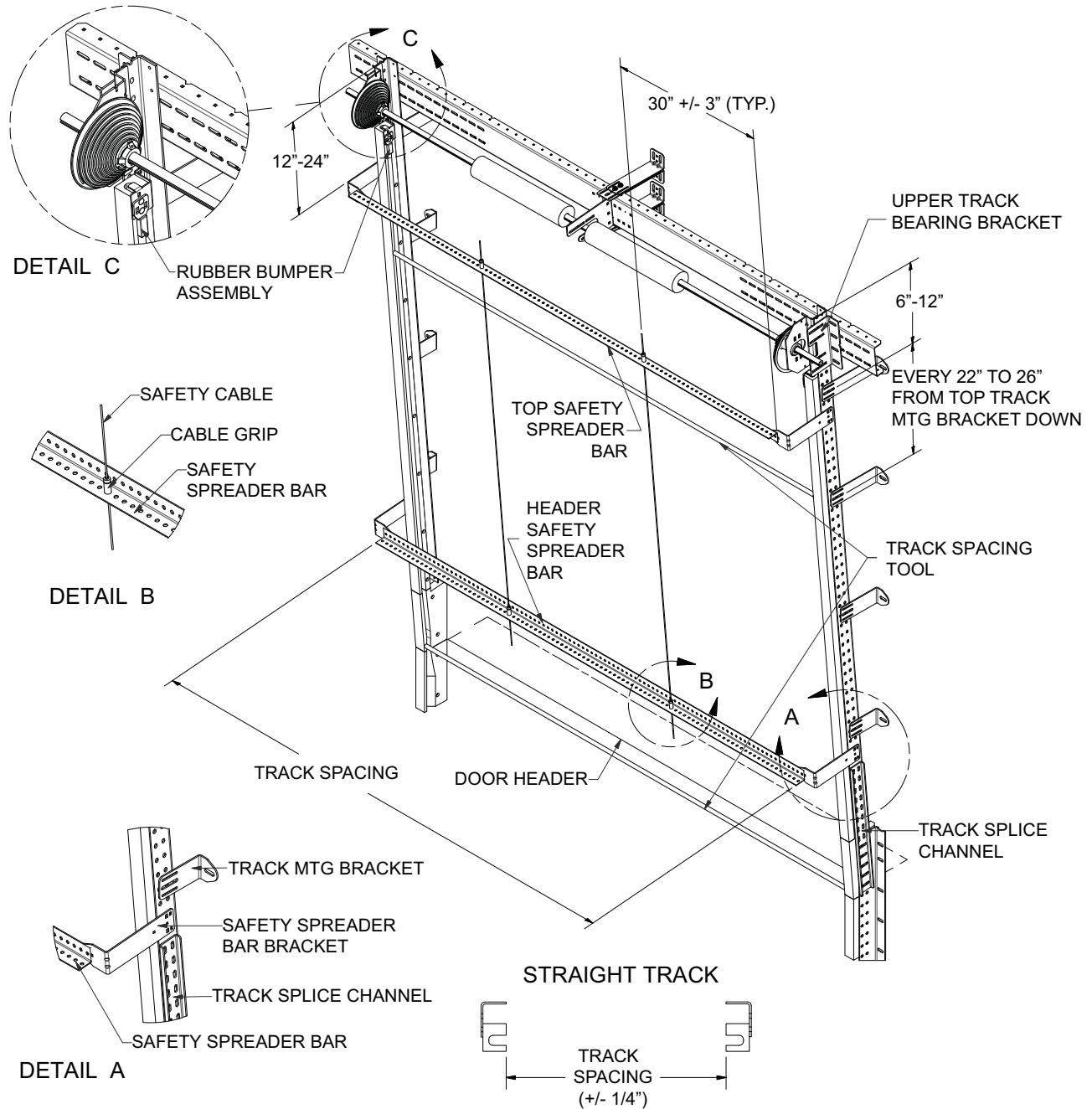

⚠ WARNING

All TKO Dock Doors [except Straight Verticals (SV)] require Safety Spreader Bar cross bracing and Safety Cable Assemblies to be installed in the area from the header to the top end of panel travel per the installation instructions. If the Safety Spreader Bars are not installed properly, the Tracks may spread, if impacted, and allow the door to fall. Failure to follow these instructions could result in death or serious injury.

UW TRACK INSTALLATION (continued)

TILT T2 UPPER TRACK INSTALLATION

1. Locate the TRACK PRINT PDS (Installer Detail Sheet) contained in the Owner's Parts Book. It illustrates the assembly of the track component parts.
2. Stack track on top of one another to create smooth, level transition and splice together with track splice plate. Bolt plastic track through steel angle track to the track splice channel with flat head, Phillips drive, 5/16-18 x 3" machine screws. Tracks are factory attached to the steel angle with flat head, Phillips drive, 5/16-18 x 2-1/2" machine screws. Pieces MUST fit together to give a smooth transition. Any sharp edges may cause plunger damage or cable failure. Track will angle away from wall at approximately a 5° angle, (Rise 12", Run 1").
3. Assemble the Bearing Plate to the Bearing Plate Mounting Bracket as illustrated below.

ITEM	QTY	PART NUMBER	DESCRIPTION
1	2	20-00840	BRG PLT-AF, UW, HL/T2
2	12	10-00035	BOLT, CRG, 3/8-16X1"
3	12	10-00006	NUT, FLNG, 3/8-16
4	2	20-01603	UPPER TRACK BRG BRACKET, UW

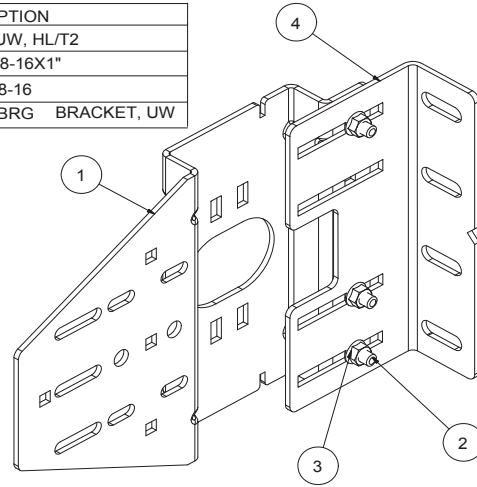

4. Attach the Bearing Plate Assembly (1) shown above to the Bearing Plate Offset Bracket (2). Do not apply full torque to the fasteners at this time. The bracket may need to be adjusted to ensure proper track alignment. The tracks need to be equally spaced from the wall surface and must maintain the correct TRACK SPACING dimension (engraved on the door mounted Safety Decal).
5. Level track then anchor the Bearing Plate Assembly (minimum of 3 anchors) to the building structure using one of the Recommended Anchoring Methods illustrated below. Tighten bolts on bearing plate and mounting bracket. Follow manufacturer's recommendations for anchor installation.

NOTE: ALL METHODS OF UPPER TRACK ANCHORING REQUIRE THE TRACK SPACING TOLERANCES OF +/- 1/4" ARE NOT EXCEEDED.

RECOMMENDED

MOUNTING TRACK TO C-90 HOLLOW CONCRETE BLOCK

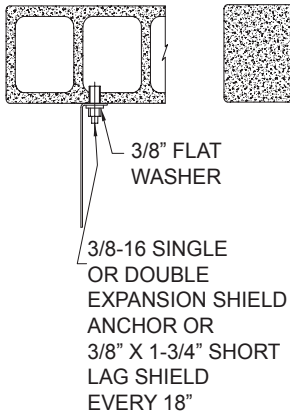

MOUNTING TRACK TO FILLED BLOCK OR SOLID CONCRETE

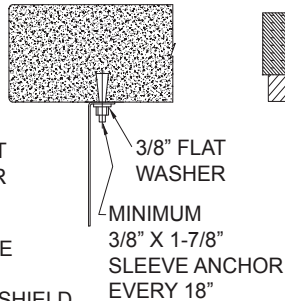

MOUNTING TRACK TO WOOD BACKED BY A SOLID MATERIAL

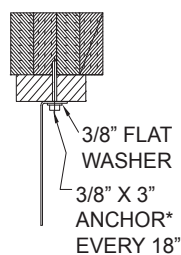

MOUNTING TRACK TO STRUCTURAL STEEL

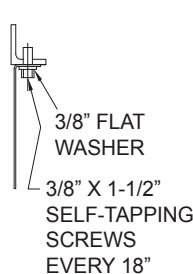

*: TYPE OF ANCHOR USED WILL BE OF SUITABLE LENGTH AND APPROPRIATE FOR TYPE OF SOLID BACKING BEHIND WOOD.

ALTERNATE

MOUNTING TRACK TO STRUCTURAL STEEL WITH FILLET WELDS



MOUNTING TRACK TO STRUCTURAL STEEL WITH PLUG WELDS

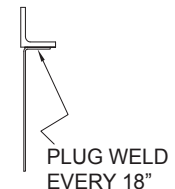

UW TRACK INSTALLATION (continued)

TILT T2 UPPER TRACK INSTALLATION

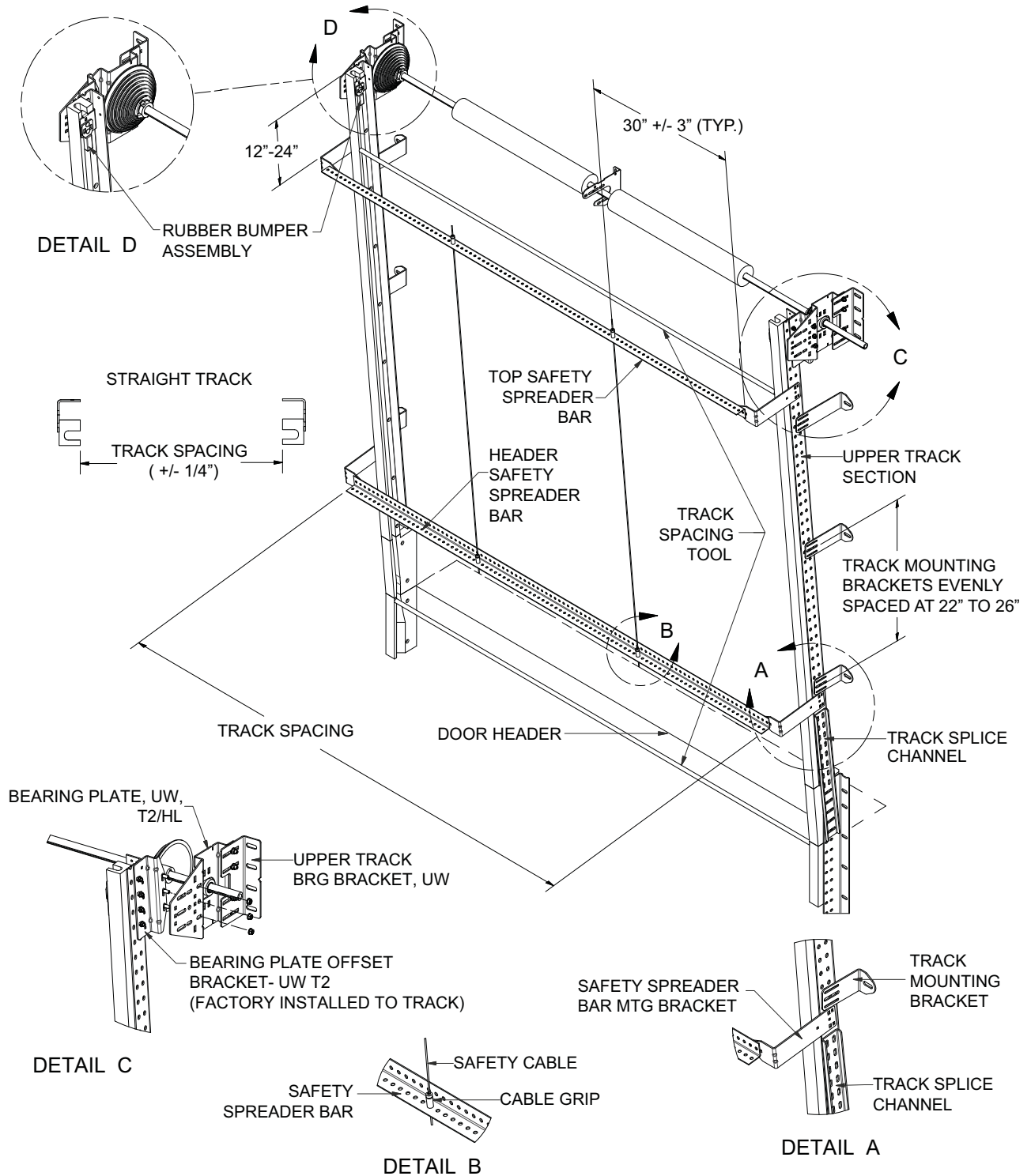

WARNING

Failure to securely position and anchor door tracks per the TRACK SPACING dimension and tolerance (engraved on the door mounted Safety Decal) may allow the tracks to become too wide and allow the door to fall out of its tracks which could result in death or serious injury.

UW TRACK INSTALLATION (continued)

TILT T2 UPPER TRACK INSTALLATION (continued)

6. Repeat steps 2 through 5 above for the opposite track. Position the track at the TRACK SPACING dimension engraved on the Serial Number tag that is attached to the third panel of each door.
7. Mount the Track Mounting Brackets evenly spaced at 22" to 26" starting right above the track splice channel at the header header (See page 43). Verify the TRACK SPACING dimension and properly torque (23 ft-lb) the fasteners that attach brackets to the track. Tighten the track anchors to the proper torque specified by the anchor manufacturer.
8. Install Safety Spreader Bar assembly: Mount safety spreader bar brackets to straight track with 5/16-18 x 3/4" carriage bolts and flange nuts. Brackets need to be attached right above the track splice channel at the header and 12" to 24" below top of tracks (See pg.43). Mount two (2) safety spreader bars horizontally from brackets and attach to brackets with 5/16-18 x 3/4" carriage bolts and flange nuts. Repeat for both sides.
9. Install two (2) Safety Cables: Bolt two (2) safety cable spool end to the top horizontal safety spreader bar approximately 30" from each end. Attach two (2) cable grip devices to bottom safety spreader bar approximately 30" from each end. Feed cable through the cable grip device and pull tight. Trim excess wire.

▲ WARNING

All TKO Dock Doors [except Straight Verticals (SV)] require Safety Spreader Bar cross bracing and Safety Cable Assemblies to be installed in the area from the header to the top end of panel travel per the installation instructions. If the Safety Spreader Bars are not installed properly, the Tracks may spread, if impacted, and allow the door to fall. Failure to follow these instructions could result in death or serious injury.

UW TRACK INSTALLATION (continued)

TILT T2 UPPER TRACK INSTALLATION

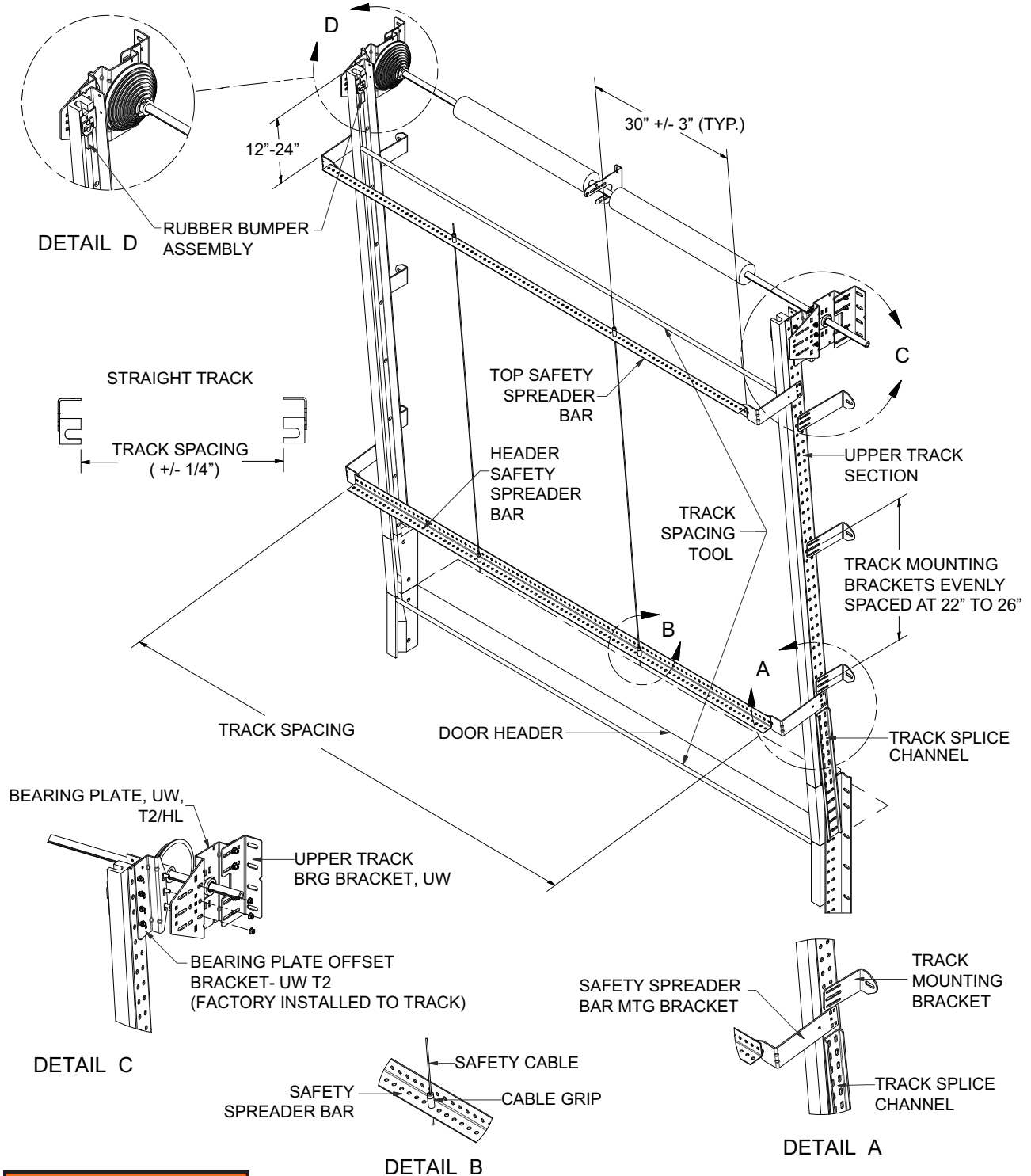

⚠ WARNING

Failure to securely position and anchor door tracks per the TRACK SPACING dimension and tolerance (engraved on the door mounted Safety Decal) may allow the tracks to become too wide and allow the door to fall out of its tracks which could result in death or serious injury. Shims may be required between the bearing plates and wall surface to ensure the TRACK SPACING is maintained and that the tracks are anchored securely.

UW TRACK INSTALLATION (continued)

ROOF PITCH UPPER TRACK INSTALLATION

1. Locate the TRACK PRINT PDS (Production Detail Sheet) contained in the Owner's Parts Book. It illustrates the assembly of the track component parts.
2. Identify upper supports: Identify a beam or structure to attach the end of the horizontal tracks. You will need to run back-hangs from this structure to the ends of the horizontal tracks once they are up. DO NOT use safety spreader angle for this purpose.
3. Attach upper track to lower: Attach pieces with 5/16-18 x 3" machine screws and flange nuts. Pieces MUST fit together to give a smooth transition. Any sharp edges may cause plunger damage or operational issues. (Low headroom roof pitch tracks mount transition to radius assembly.) Shimming may be required to ensure that the upper tracks are in line with the lower tracks.
4. Mount horizontal track: Horizontal tracks are factory attached to the radius and the bearing plate. Using proper lifting techniques, have helper hold up horizontal track assembly while mounting radius to vertical track. Secure radius to vertical track section with flat head, Phillips drive, 5/16-18 x 2-1/2" machine screws and flange nuts. Level track then mount vertical track section to wall using one of the Recommended Anchoring methods listed below. Anchors/fasteners should be placed on top of track then filled in every 18". Track MUST BE level and at proper spacing or door will not work correctly. Follow manufacturer's recommendations for anchor installation.
5. Repeat for the opposite side: Measure and verify that the TRACK SPACING dimension (engraved on the door mounted Safety Decal) is correct before mounting angle to wall.

NOTE: ALL METHODS OF UPPER TRACK ANCHORING REQUIRE THE TRACK SPACING TOLERANCES OF +/- 1/4" ARE NOT EXCEEDED.

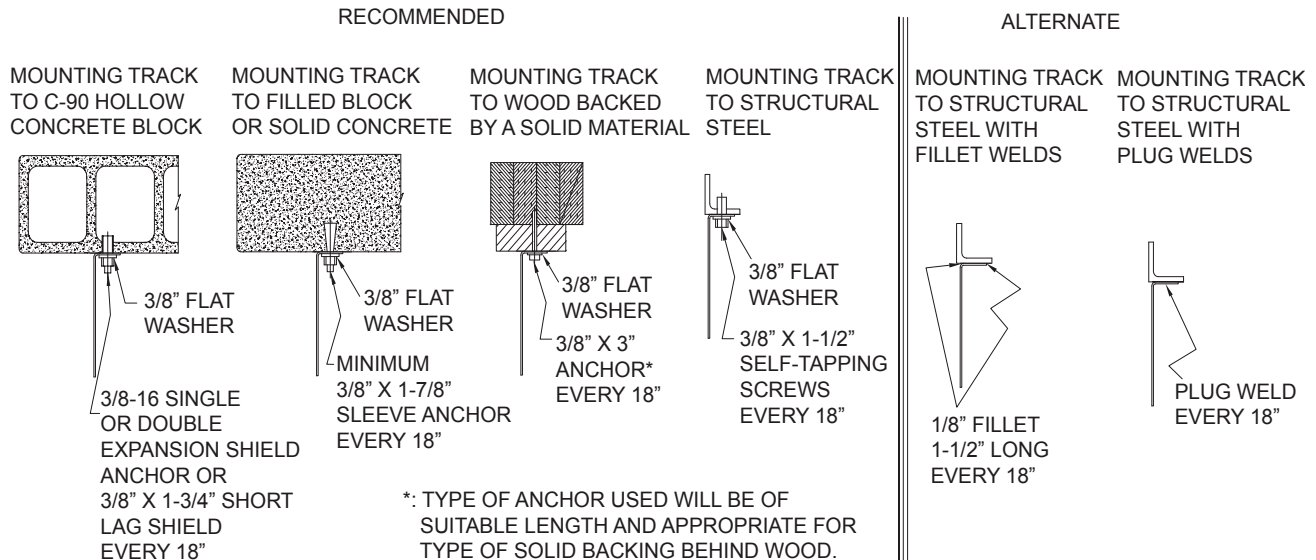

⚠ WARNING

Failure to securely position and anchor door tracks per the TRACK SPACING dimension and tolerance (engraved on the door mounted Safety Decal) may allow the tracks to become too wide and allow the door to fallout of its tracks which could result in death or serious injury. Shims may be required between the track/end bearing plates and wall surface to ensure the TRACK SPACING is maintained and that the tracks are anchored securely.

All TKO Dock Doors [except Straight Verticals (SV)] require Safety Spreader Bar cross bracing and Safety Cable Assemblies to be installed in the area from the header to the top end of panel travel per installation instructions. If the Safety Spreader Bars are not installed properly, the Tracks may spread, if impacted, and allow the door to fall. Failure to follow these instructions could result in death or serious injury.

UW TRACK INSTALLATION (continued)

ROOF PITCH UPPER TRACK INSTALLATION (continued)

6. Install safety spreader bar assemblies: Attach safety spreader bar brackets 6" to 12" from the radius, 6" to 12" from end of horizontal track and right above the track splice channel at the header. Mount brackets to track using 5/16-18 x 3/4" carriage bolts and flange nuts. Attach a total of 3 safety spreader bars to the brackets using 5/16-18 x 3/4" carriage bolts and flange nuts. **DO NOT** tighten bolts until backhangs and sway bracing have been installed. Repeat for both sides. Spreader bars should run from one track side to the other to keep track from separating. Center and bolt safety cable spool end to back horizontal spreader bar. Attach cable grip device to bottom spreader bar at the header. Wrap cable over the middle safety spreader bar and fasten with cable tie. Feed cable through the cable grip device and pull tight. Trim excess wire.
7. Attach back-hangs: Verify that tracks retain proper spacing. Move tracks to necessary width and tie into structure or ceiling with 12 gauge minimum steel angle/back-hang. Sway bracing must also be attached to back-hangs to prevent tracks from moving. Fasten sway bracing only after tracks are aligned and parallel with panels when door is in UP Position. Attachment of back-hang material to the surrounding structure must be in compliance with all local and state building codes for the specific location.

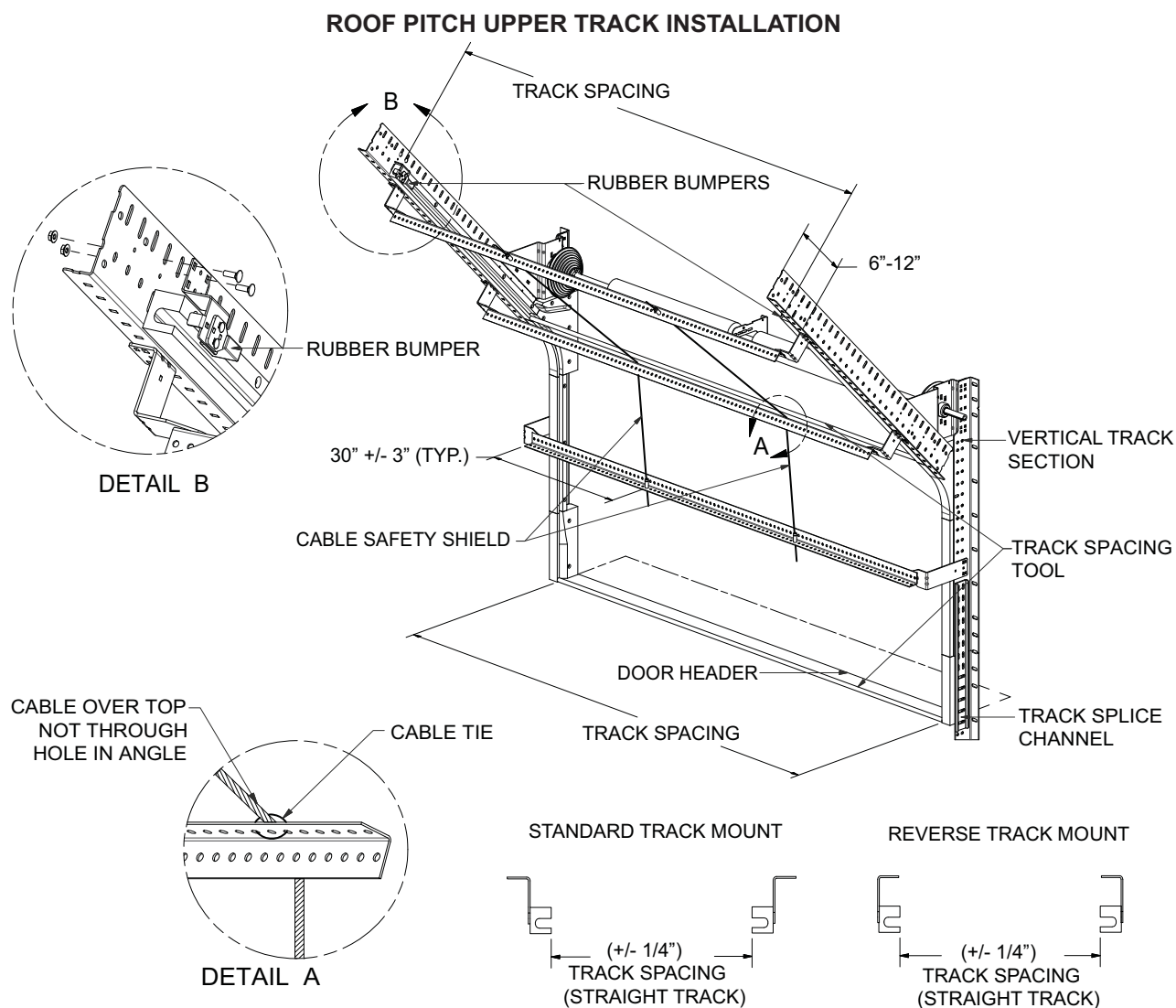

UW TRACK INSTALLATION (continued)

HIGH-LIFT UPPER TRACK INSTALLATION

1. Locate the TRACK PRINT PDS (Production Detail Sheet) contained in the Owner's Parts Book. It illustrates the assembly of the track component parts.
2. Identify upper supports: Identify a beam or structure to attach the end of the horizontal tracks. You will need to run back-hangs from this structure to the ends of the horizontal tracks once they are up. DO NOT use safety spreader angle for this purpose.
3. Attach upper track to lower: Attach pieces with flat head, Phillips drive, 5/16-18 x 2-1/2" machine screws. Pieces MUST fit together to give a smooth transition. Any sharp edges may cause plunger damage and/or operational issues. (Low headroom roof pitch tracks mount transition to radius assembly.) Shimming may be required to ensure that the upper tracks are anchored securely and in line with the lower tracks.
4. Mount horizontal track: Horizontal tracks are factory attached to the radius. Using proper lifting techniques, have helper hold up horizontal track assembly while mounting radius to vertical track. Secure radius to vertical track with flat head, Phillips drive, 5/16-18 x 2-1/2" machine screws and flange nuts. Level track then mount vertical track section to wall using one of the Recommended Anchoring methods listed below. Anchors/fasteners should be placed on top of track then filled in every 18". Tracks MUST BE level and at proper spacing or door will not work correctly. Follow manufacturer's recommendations for anchor installation.
5. Repeat for the opposite side: Measure and verify that the TRACK SPACING dimension (engraved on the door mounted Safety Decal) is correct before mounting angle to wall.

NOTE: ALL METHODS OF UPPER TRACK ANCHORING REQUIRE THE TRACK SPACING TOLERANCES OF +/- 1/4" ARE NOT EXCEEDED.

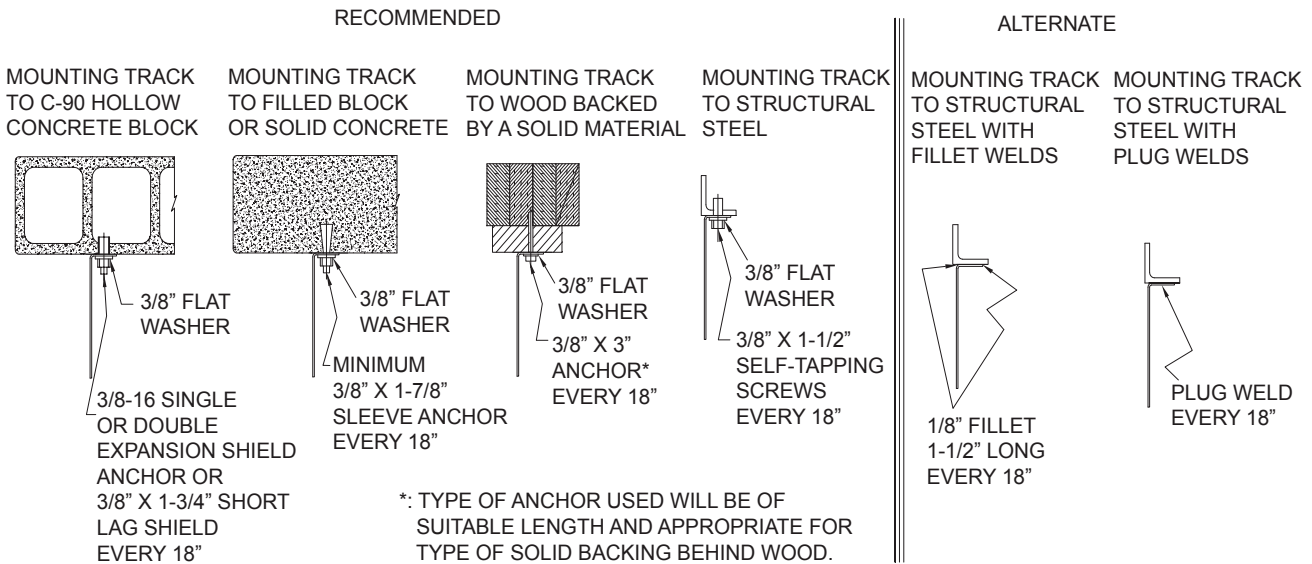

⚠ WARNING

Failure to securely position and anchor door tracks per the TRACK SPACING dimension and tolerance (engraved on the door mounted Safety Decal) may allow the tracks to become too wide and allow the door to fall out of its tracks which could result in death or serious injury. Shims may be required between the track and wall surface to ensure the TRACK SPACING is maintained and that the tracks are anchored securely.

All TKO Dock Doors [except Straight Verticals (SV)] require Safety Spreader Bar cross bracing and Safety Cable Assemblies to be installed in the area from the header to the top end of panel travel per installation instructions. If the tracks are not firmly stabilized with the Spreader Bars, the Tracks may injury, spread and allow the door to fall. Failure to follow these instructions could result in death or serious injury.

UW TRACK INSTALLATION (continued)

HIGH-LIFT UPPER TRACK INSTALLATION (continued)

6. Install spreader bar assembly: Attach spreader bar brackets 6" to 12" before radius, 6" to 12" from end of horizontal track and right above the track splice channel at the header. Mount brackets to track using 5/16-18 x 3/4" carriage bolts and flange nuts. Attach a total of 3 spreader bars to the brackets using 5/16-18 x 3/4" carriage bolts and flange nuts. DO NOT tighten bolts until backhangs and sway bracing have been installed. Repeat for both sides. Spreader bars should run from one track side to the other to keep track from separating. Center and bolt safety cable spool end to back horizontal spreader bar. Attach cable grip device to bottom spreader bar at the header. Wrap cable over the middle spreader bar and fasten with cable tie. Feed cable through the cable grip device and pull tight. Trim excess wire.
7. Attach back-hangs: Verify that tracks retain proper spacing. Move tracks to necessary width and tie into structure or ceiling with 12 gauge minimum steel angle/back-hang. Sway bracing must be also attached to back-hangs to prevent tracks from moving. Fasten sway bracing only after tracks are aligned and parallel with panels when door is in UP position. Attachment of back-hang material to the surrounding structure must be in compliance with all local and state building codes for the specific location.

HIGH-LIFT UPPER TRACK INSTALLATION

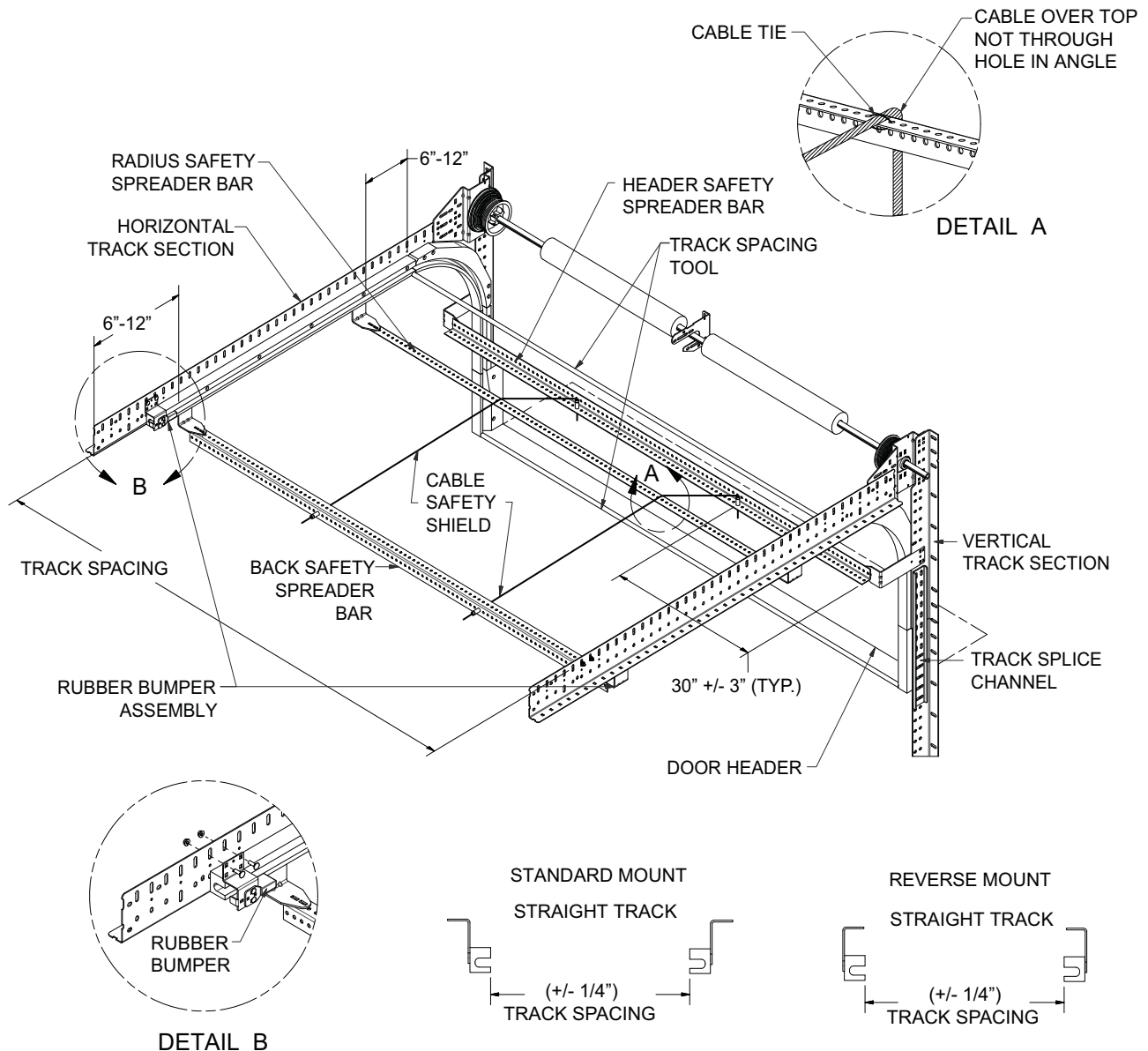

PANEL INSTALLATION

⚠ WARNING

DO NOT allow side seals to compress in any way before panels are actually stacked in opening.

COMPONENT IDENTIFICATION

1. Identify panels:
 - Inspect panels for any missing or damaged panels. Call TKO doors or local distributor/ dealer if assistance is required.
2. Bottom panel:
 - The bottom panels have a horizontal (dual bulb) seal on the top of the panel and a loop seal on the bottom.
 - In most cases, this panel is 24" high.
3. Second and Third panels:
 - The Second and Third panels have a horizontal (dual bulb) seal on the top and bottom of the panel.
 - This panel could be 18" or 24" high depending on door height. Smaller panels are always installed above larger panels.
 - If a window panel was supplied, it is typically placed in the 3rd panel from bottom position.
4. Fourth and Higher panels:
 - The Fourth and Higher panels have a horizontal (dual bulb) seal on the top and bottom of the panel.
 - This panel could be 18" or 24" high depending on door height.

⚠ WARNING

Fixed plungers are required on the Fourth and Higher panels when the counterbalance cable attachment is NOT at the top of the door.

5. Top panel:
 - The top panels have a T-Slot seal on the top of the panel and a horizontal (dual bulb) seal on the bottom.
 - This panel could be 12", 18" or 24" high depending on door height.

NOTE: For top panel pickup cable brackets the cable must be attached to the outer most location on the bracket. (See illustration on pg. 49)

PLUNGER DESCRIPTION

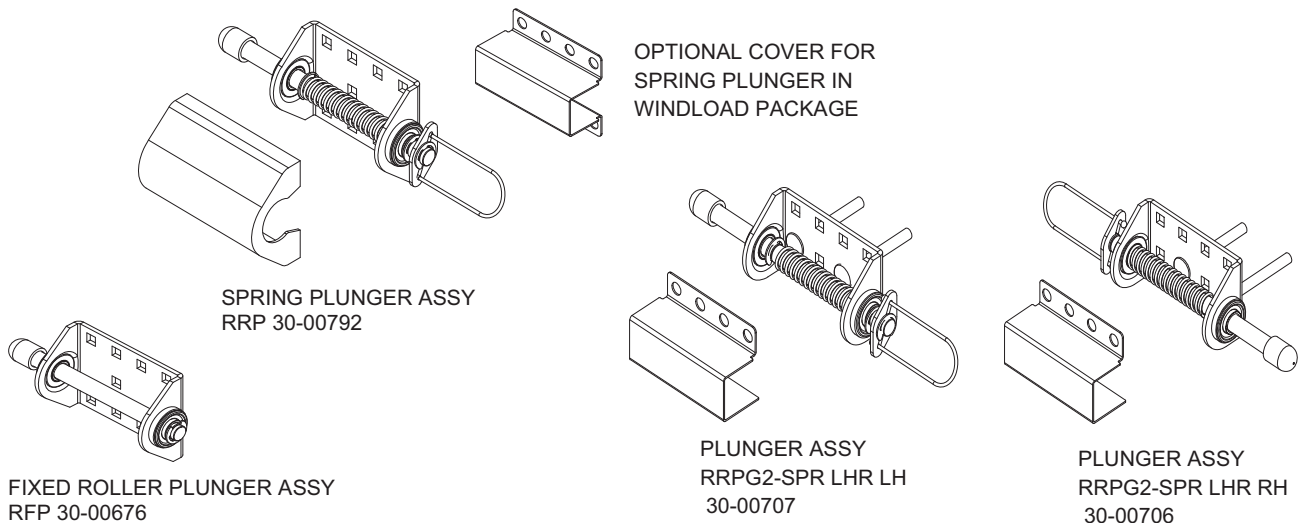

PANEL INSTALLATION (continued)

⚠ WARNING

Fixed plungers are required on the Fourth and Higher panels when the counterbalance cable attachment is NOT at the top of the door.

FULL DOOR PANEL ASSEMBLY

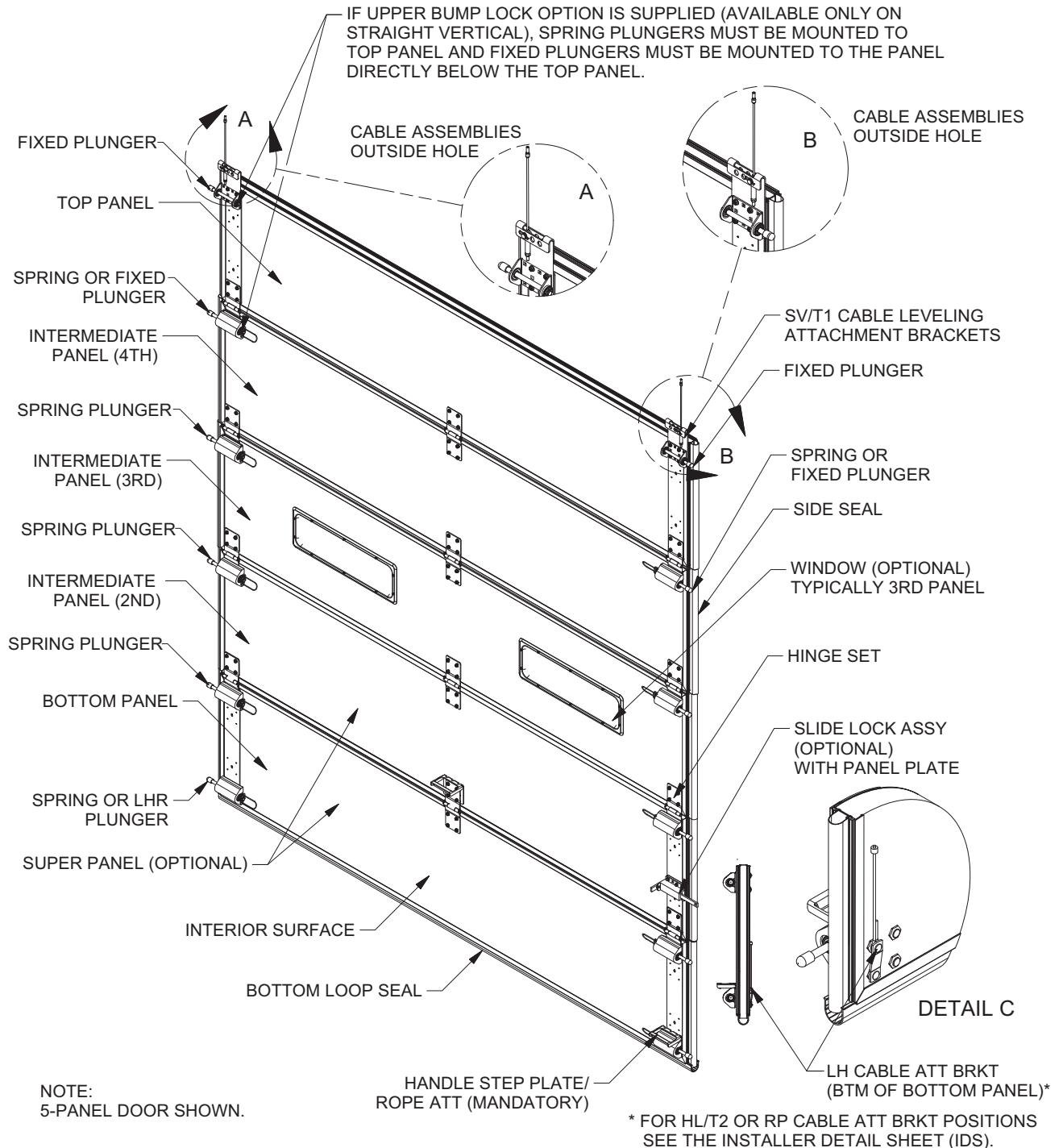

PANEL INSTALLATION (continued)

PANEL STACKING - OVERVIEW

1. Assembling panels:
 - Identify any specific door order specifications including any/all panel accessory options before stacking Panels . See Panel PDS (Production Detail Sheet) and Panel Hardware PDS (Production Detail Sheet) in the Owner's Parts Book.
 - Identify the proper cable bracket mounting location.
 - Identify the # of door panels per door, and their stacking sequence.
 - If upper bump lock option is supplied (available only with straight vertical track), spring plungers must be mounted to top panel and fixed plungers must be mounted to the panel directly below the top panel.
 - Lube plunger spring shafts and bearings with Light oil prior to stacking panels. With covers off, spray plunger shafts thoroughly so that contact points of housing, shafts, and bearings are covered.
 - For top-pickup styles, Install cables to the outside set of holes of the lift brackets.

▲ WARNING

Fixed plungers are required on the Fourth and Higher panels when the counterbalance cable attachment is NOT at the top of the door.

PANEL INSTALLATION (continued)

PANEL STACKING

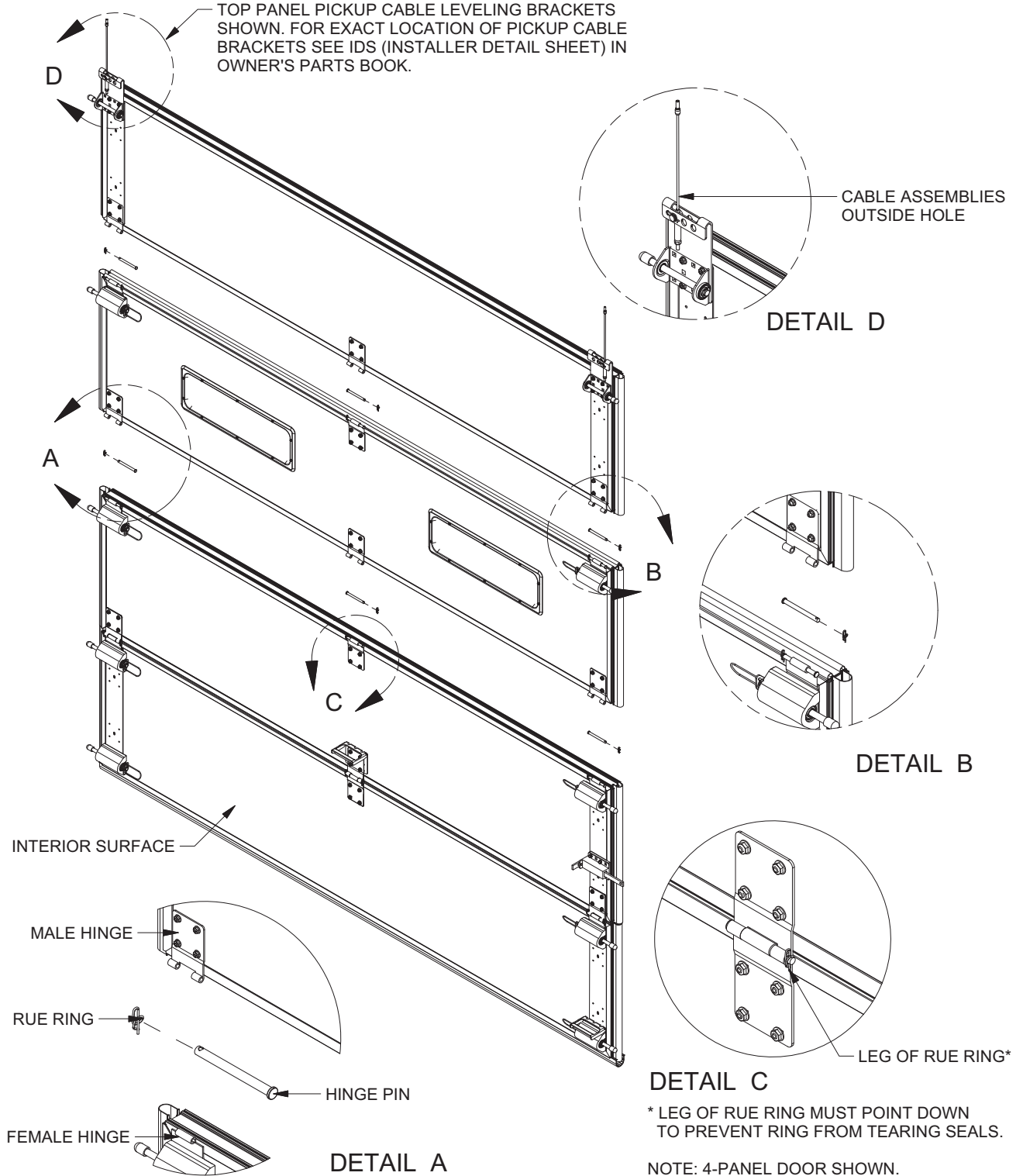

PANEL INSTALLATION (continued)

SLIDE LOCK INSTALLATION

1. Identify quantity of slide lock assemblies to be installed and customer desired location(s).
2. Position slide lock assembly so that slide lock bar is level and in-line with slide lock hole on track when door is fully closed and creating proper seal at bottom.
3. Install slide lock assembly to panel plate using (4) TEK screws. Spacer blocks are included for any non-top pickup doors. Spacer blocks are installed between the slide lock housing and panel plate. Slide lock bar **MUST** extend through the track allowing proper clearance of lock hole when bar is engaged. Slide lock housing should not extend beyond retainer edge on panel.

SLIDE LOCK INSTALLATION

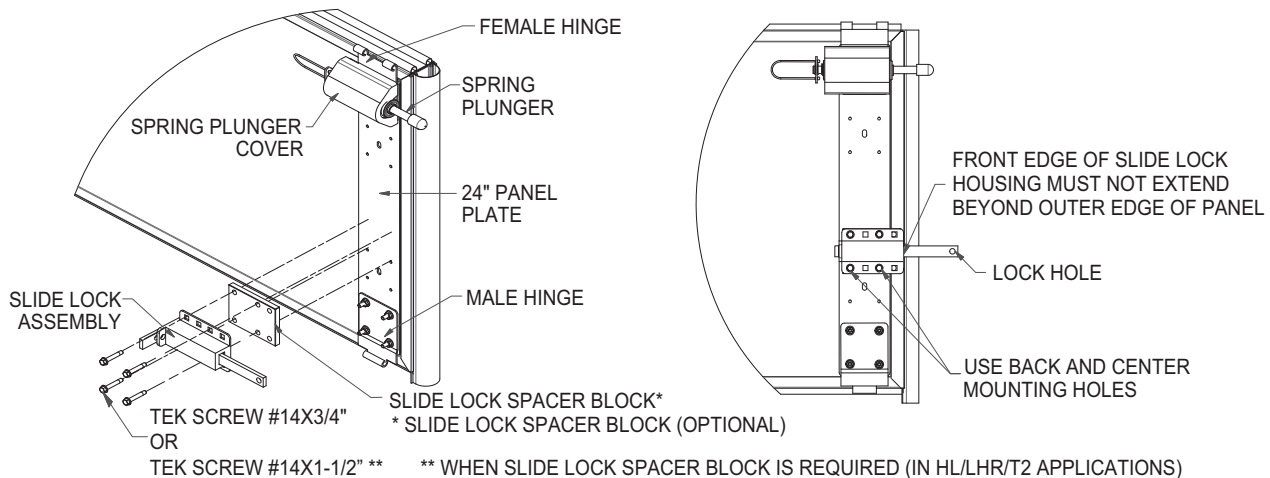

LINTEL SEAL INSTALLATION

A. Blade Seal (2" blade on 1" straight retainer-2 sets included for installation on both header and top panel)

Header Installation:

1. Measure each individual jamb width at the header, then cut retainer and blade to these exact measurements.
2. Install blade on to retainer.
3. Hold retainer (flat side up) to header and adjust in towards the panel just enough to create a good seal across panel width.

NOTICE

Forcing the blade too far into the panel will result in excessive drag and poor door operation.

4. Install assembly to header using appropriate fasteners (not included) at each end, then every 15" to 20".

Top Panel Installation:

1. Measure width of top panel (less side seals) then cut aluminum retainer to this length.
2. Measure track width just above top of door then cut blade to this measurement.
3. Install blade on to retainer (position so blade ends are equal distance away from retainer ends).
4. Position retainer (flat side down) so it is even with panel ends, then adjust in towards header/wall just enough to create a uniform seal across the opening width.

NOTICE

Forcing the blade too far into header/wall will result in excessive drag and poor door operation.

5. Fasten assembly to panel top using supplied screws at each end, then every 15" to 20" after.

B. Brush Seal (Single 2" brush on 1" straight retainer are sent as standard.)

1. Brush seals may be mounted to header or panel top. Choice determined by best sealing result.
2. Follow same installation instructions outlined for the Blade Seals above.

PANEL INSTALLATION (continued)

DECALS & PLACARD INSTALLATION

The Safety Decal (Part Number 15-00053) and Product Identification Decal are factory installed to the third panel on the right side as shown in the illustration below. The installer must post the Warning Placard next to the door in a viewable location for the operators of the door.

DECALS & PLACARD INSTALLATION

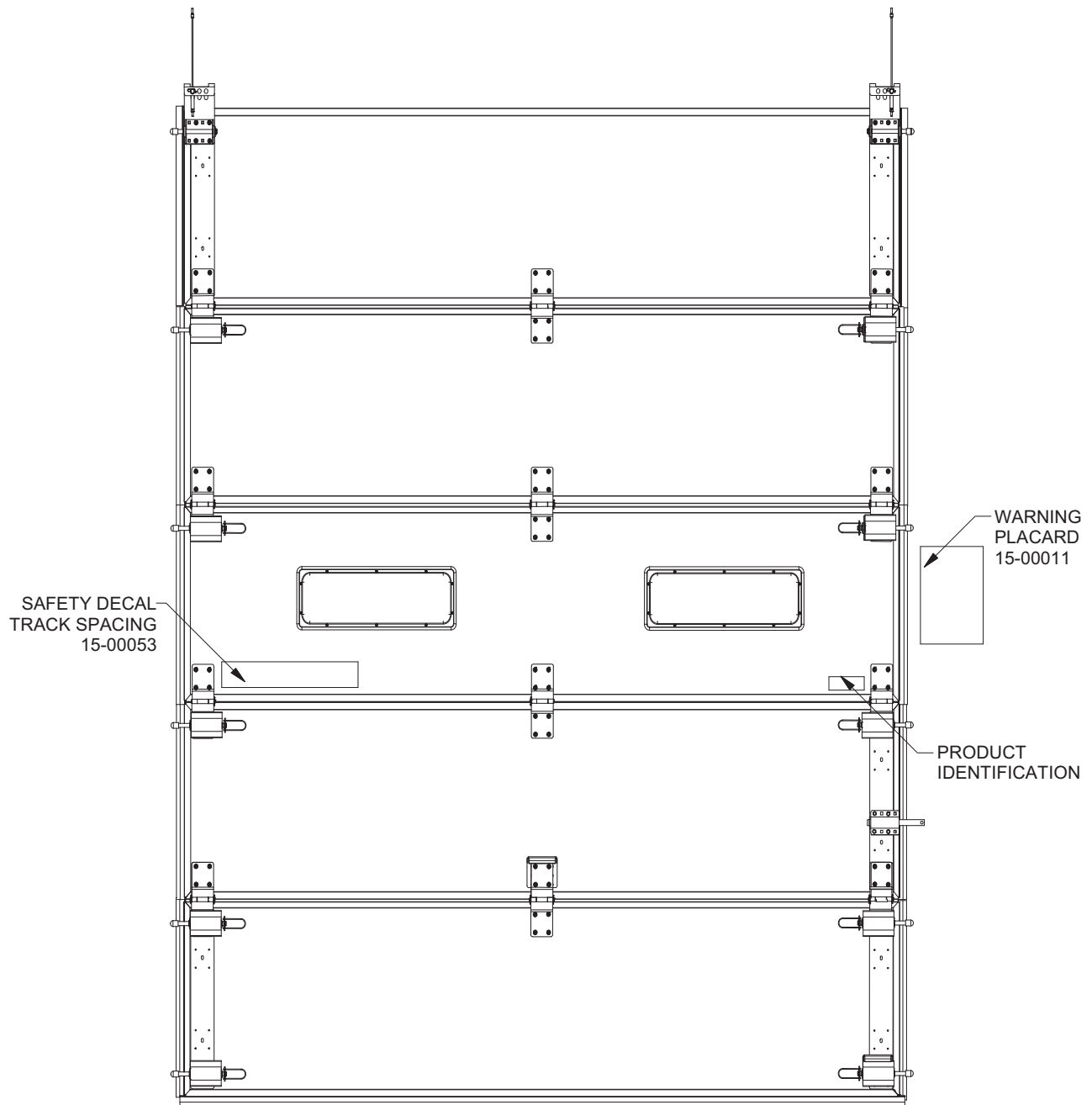

PANEL INSTALLATION (continued)

DECALS & PLACARD INSTALLATION (continued)

The Safety Decal contains the Track Spacing Dimension, Serial Number, and Model Name. Inspect each door every 30 days to ensure that this decal is still fastened to the door and is legible. If the Safety Decal is not present, contact the factory to obtain a replacement Safety Decal.

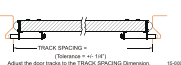
<p>WARNING</p> <ul style="list-style-type: none"> • Read and follow all warnings and instructions in the Owner's Manual, the Safety Decal, and all warning placards. • Personnel using the dock doors must be properly trained. • NEVER use damaged or malfunctioning dock doors. Report problems immediately to supervisor. • Operate door only when it is properly adjusted and free of obstructions. Should the door become difficult to operate or completely inoperative, immediately report to supervisor. • DO NOT throw door up violently. Using excessive force to open the door may cause the door cables to jump or door panels to disengage from tracks. • DO NOT close door onto obstructions. Obstructions in the opening may stop the door's movement and cause the door cables to jump or door panels to disengage from tracks. • TRACK SPACING tolerances MUST always be maintained with tracks securely mounted before door is operated. • Operating door with improper TRACK SPACING or mounting could cause panels to disengage from the track, which could crush you and cause death or serious injury. Refer to Owner's Manual and this placard for proper track spacing and mounting requirements. • Impacting this door can create a hazardous situation. ALWAYS use caution and carefully follow instructions listed on this placard. • ALWAYS follow maintenance schedule to ensure all components are in good working condition. Damaged or worn parts must be replaced immediately for proper and safe operation. It is recommended that the door be made inoperative until the damaged or worn parts have been replaced. • The cable attachment bracket is under extreme spring tension. DO NOT try to adjust or repair. Repairs or adjustments must be made by a trained door systems technician using proper tools and instructions. The cable attachment bracket can spring out and hit someone, which could result in death or serious injury. This product is manufactured by TKO DOCK DOORS. Covered by one or more of the following U.S. Patents: Various Foreign Patents, under U.S. and Foreign Patents: Pending: US5055, 6541 (84), 650222, 6237373. 	<p>DOOR OPERATION</p> <p>To operate, keep door in full view, slowly raise door using manufacturer supplied handle(s) and lower door by slowly pulling on supplied pull down rope. NEVER apply force in a manner which would cause the panels to disengage from the track. If door has an automatic opener, remove pull rope from door and follow instructions supplied with opener.</p> <p>RESET IMPACTED PANELS</p> <ol style="list-style-type: none"> 1. In the event of a panel KNOCKOUT or track impact situation, step away from the door a safe distance. 2. Inspect the door system BEFORE resetting panels. <ul style="list-style-type: none"> ➢ Plungers of the top panel must be engaged in track. ➢ Cables must be properly tensioned and seated in the grooves of the cable drums. ➢ Panels must be sitting level with hardware intact. ➢ Tracks must be square to jamb face and securely mounted. <p>If the above conditions are met, continue with resetting door (see steps 3-6 below). If any of these conditions are not met, DO NOT use door. Stay clear of door and immediately report incident to supervisor and have a trained door systems technician inspect and reset door.</p> <ol style="list-style-type: none"> 3. Clear fork truck and/or all product from dock door area. 4. Grab manufacturer supplied handle(s) and pull door panels back into tracks. If the spring plunger tips are obstructed at any point of the return travel, the plunger rods may be manually retracted while pulling panels back into tracks. Depending on conditions, this operation may require 2 people to safely reset the door. <ul style="list-style-type: none"> • NEVER try to open or close door until all panel plungers are reset back into track and door has been inspected. • NEVER climb under impacted panels to reset door. 5. Check panels, track, hardware and fasteners for any damage, looseness, misalignment and verify TRACK SPACING BEFORE operating door. 6. After panels have been engaged back into the tracks, carefully cycle the door to its fully open and closed position several times making sure operation is smooth throughout its entire travel cycle. <p>Failure to follow these and other provided warnings could result in death or serious injury.</p>	<p>SAFETY INSTRUCTIONS</p> <p>No overhead door is a safe haven. Impact that moves with the help of springs under extreme tension. Moving objects and persons may become airborne and/or serious injury. Call 800-675-3288 for free additional placards, manuals and with questions regarding proper use, maintenance and repair of dock doors.</p> <ol style="list-style-type: none"> 1. DO NOT stand or walk under moving door. Keep door in full view and use proper technique while operating. 2. DO NOT throw door up violently. Using excessive force to open the door may cause the door cables to jump or door panels to disengage from tracks. 3. DO NOT close door onto obstructions. Obstructions in the opening may stop the door's movement and cause the door cables to jump or door panels to disengage from tracks. 4. Operating door with improper TRACK SPACING or mounting could cause panels to disengage from the track, which could crush you and cause death or serious injury. Refer to Owner's Manual and this placard for proper track spacing and mounting requirements. 5. DO NOT try to open or close door until all panel plungers are reset back into track and door has been inspected. 6. NEVER climb under impacted panels to reset door. <p>BEFORE operating door.</p> <ol style="list-style-type: none"> 1. After panels have been engaged back into the tracks, carefully cycle the door to its fully open and closed position several times making sure operation is smooth throughout its entire travel cycle. <p>Failure to follow these and other provided warnings could result in death or serious injury.</p>	<p>WARNING</p>  <p>MOVING DOOR CAN RESULT IN SERIOUS INJURY OR DEATH. DO NOT CLOSE DOOR UNTIL DOORWAY IS CLEAR.</p> <p>STRANGE, BOTTOM BRACKET, RED COLORED PISTONS ONLY IDENTIFY FASTENERS, CABLES AND SUPPORTS AND MAKE EXTENSIVE CHECKS AND CAN CAUSE SERIOUS INJURY OR DEATH.</p>	<p>TKO DOCK DOORS</p> <p>TKO INDUSTRIES N. Corporate Circle • Sussex, WI 53089 Phone: (262) 242-1217 Fax: (262) 242-1217 Call 800-675-3288 for free additional placards, manuals and with questions regarding proper use, maintenance and repair of dock doors.</p> <p>Model Name: TKO-ThermalWall®</p>  <p>Adjust the door tracks to the TRACK SPACING Dimension</p>
---	---	--	---	--

The Warning Placard (Part Number 15-00011) illustrated below must be posted by the installer next to the door visible to the users of the door. Inspect each door every 30 days to ensure that this placard is still posted near the door and is legible. Replace as necessary.



- Read and follow all warnings and instructions in the Owner's Manual, door mounted Safety Decal, and this wall mounted Placard.
- Personnel using the dock doors must be properly trained.
- NEVER use damaged or malfunctioning dock doors. Report problems immediately to supervisor.
- Operate door only when it is properly adjusted and free of obstructions. Should the door become difficult to operate or completely inoperative, immediately report to supervisor.
- DO NOT throw door up violently. Using excessive force to open the door may cause the door cables to jump or door panels to disengage from tracks.
- DO NOT close door onto obstructions. Obstructions in the opening may stop the door's movement and cause the door cables to jump or door panels to disengage from tracks.
- TRACK SPACING tolerances MUST always be maintained with tracks securely mounted before door is operated.
- Operating door with improper TRACK SPACING or mounting could cause panels to disengage from the track, which could crush you and result in death or serious injury. Refer to Owner's Manual and Safety Decal mounted on door for proper TRACK SPACING and mounting requirements.
- Impacting this door can create a hazardous situation. ALWAYS use caution and carefully follow instructions listed on this Placard and the door mounted Safety Decal.
- ALWAYS follow maintenance schedule to ensure all components are in good working condition. Damaged or worn parts must be replaced immediately for proper and safe operation. It is recommended that the door be made inoperative until the damaged or worn parts have been replaced.
- The cable attachment bracket is under extreme spring tension. DO NOT try to adjust or repair. Repairs or adjustments must be made by a trained door systems technician using proper tools and instructions. The cable attachment bracket can spring out and hit someone, which could result in death or serious injury.

DOOR OPERATION

To operate, keep door in full view, slowly raise door using manufacturer supplied handle(s) and lower door by slowly pulling on supplied pull down rope. NEVER apply force in a manner which would cause the panels to disengage from the track. If door has an automatic opener, remove pull rope from door and follow instructions supplied with opener.

RESET IMPACTED PANELS

1. In the event of a panel KNOCKOUT or track impact situation, step away from the door a safe distance.
 2. Inspect the door system **BEFORE** resetting panels.
 - Plungers of the top panel must be engaged in track.
 - Cables must be properly tensioned and seated in the grooves of the cable drums.
 - Panels must be sitting level with hardware intact.
 - Tracks must be square to jamb face and securely mounted.
- If the above conditions are met, continue with resetting door (see steps 3-6 below). If any of these conditions are not met, **DO NOT** use door. Stay clear of door and immediately report incident to supervisor and have a trained door systems technician inspect and reset door.
3. Clear fork truck and/or all product from dock door area.
 4. Grab manufacturer supplied handle(s) and pull door panels back into tracks. If the spring plunger tips are obstructed at any point of the return travel, the plunger rods may be manually retracted while pulling panels back into tracks. Depending on conditions, this operation may require 2 people to safely reset the door.
 - NEVER try to open or close door until all panel plungers are reset back into track and door has been inspected.
 - NEVER climb under impacted panels to reset door.
 5. Check panels, track, hardware and fasteners for any damage, looseness, misalignment and verify TRACK SPACING **BEFORE** operating door.
 6. After panels have been engaged back into the tracks, carefully cycle the door to its fully open and closed position several times making sure operation is smooth throughout its entire travel cycle.

Failure to follow these and other provided warnings could result in death or serious injury.

<p>TKO DOCK DOORS</p>	<p>Call for additional placards, manuals or with questions regarding proper use, maintenance and repair of dock doors.</p> <p>N56 W24701 N. Corporate Circle, Sussex, WI 53089 • Phone: (262) 820-1217 • Fax: (262) 820-1273</p>	<p>P/N: 15-00011 REV: G 07/09</p>
------------------------------	--	-----------------------------------

PANEL INSTALLATION (continued)

DECALS & PLACARD INSTALLATION (continued)

The Spring Warning Tag (TKO Part Number 15-00005) must be fastened to the center bearing bracket for the counter balance springs as illustrated on the adjacent page. Inspect each door every 30 days to ensure that this tag is still fastened to shaft/spring assembly and is legible. Replace as necessary.



WARNING

HIGH SPRING TENSION CAN CAUSE SERIOUS INJURY OR DEATH.



DO NOT adjust, repair or remove springs or parts to which springs are connected, such as steel brackets, cables, wood blocks, red colored fasteners or other parts of counterbalance system.

Adjustments or repairs must ONLY be made by a trained door systems technician using proper tools and instructions.

DO NOT remove, cover or paint over this tag. Product user should inspect this tag periodically for legibility and should order a replacement tag from the door manufacturer, as needed.



1/06 CRGD-102



WARNING

HIGH SPRING TENSION CAN CAUSE SERIOUS INJURY OR DEATH.



DO NOT adjust, repair or remove springs or parts to which springs are connected, such as steel brackets, cables, wood blocks, red colored fasteners or other parts of counterbalance system.

Adjustments or repairs must ONLY be made by a trained door systems technician using proper tools and instructions.

DO NOT remove, cover or paint over this tag. Product user should inspect this tag periodically for legibility and should order a replacement tag from the door manufacturer, as needed.



1/06 CRGD-102

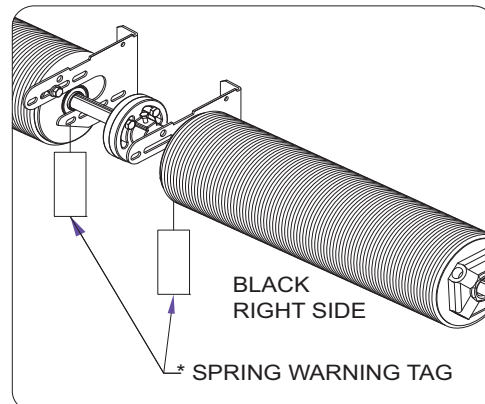
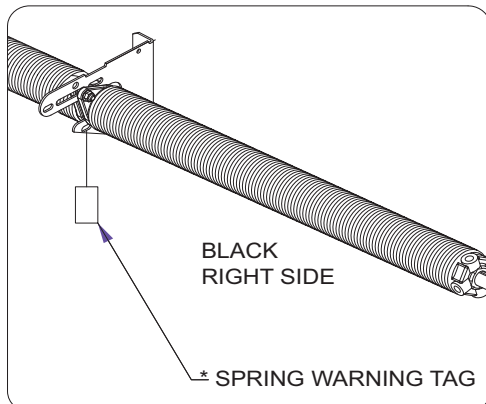

SPRING/SHAFT INSTALLATION

⚠ WARNING

Failure to properly secure the Anchor Pad could allow the Springs to violently disengage from the wall and could result in death or serious injury. NEVER use nails! It is important that the Torsion Spring Assembly is securely mounted to the wall structure.

CENTER SPRING PAD/ CENTER BEARING BRACKET INSTALLATION

1. Measure CENTER LINE OF SHAFT (C/L) and verify area for proper spring pad mounting.
2. Identify style of spring/shaft assembly supplied with door.
3. Center anchor pad(s) **MUST BE** at least 2" wide by 6" high to properly support center bearing bracket(s). Single shafts will require a single pad/bracket centered in the door opening. Dual shafts with couplers will require two pads/brackets centered in opening and spaced approximately 12 inches apart. Single shafts with Dual 6" Springs will also require two (2) pads/brackets.
4. Center anchor pad(s) **MUST** adequately support the center bearing bracket(s) and torsion spring assembly.
5. If center anchor pad is wood, pad **MUST BE** free of cracks and splits in the wood. If wood is cracked or split, it **MUST BE** replaced. **DO NOT** use wood of less than grade 2 yellow pine or wood labeled as spruce-pine-fur (SPF). Pilot drill all holes to prevent splitting of wood.
6. TKO recommends that the Center Bearing Bracket(s) not be welded. This Alternate Anchoring Method will not allow for adjustment if the spring shaft needs leveling. See illustration below for Recommended Anchoring Methods.

RECOMMENDED ANCHORING METHODS

MOUNTING BRACKET
TO C-90 HOLLOW
CONCRETE BLOCK

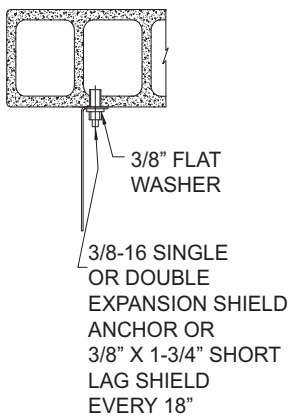

MOUNTING BRACKET
TO FILLED BLOCK
OR SOLID CONCRETE

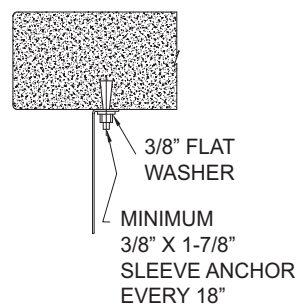

MOUNTING BRACKET
TO WOOD BACKED
BY A SOLID MATERIAL

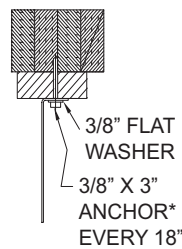

MOUNTING BRACKET
TO STRUCTURAL
STEEL



*: TYPE OF ANCHOR USED WILL BE OF SUITABLE LENGTH AND APPROPRIATE FOR TYPE OF SOLID BACKING BEHIND WOOD.

SPRING/SHAFT INSTALLATION (continued)

CENTER SPRING PAD INSTALLATION

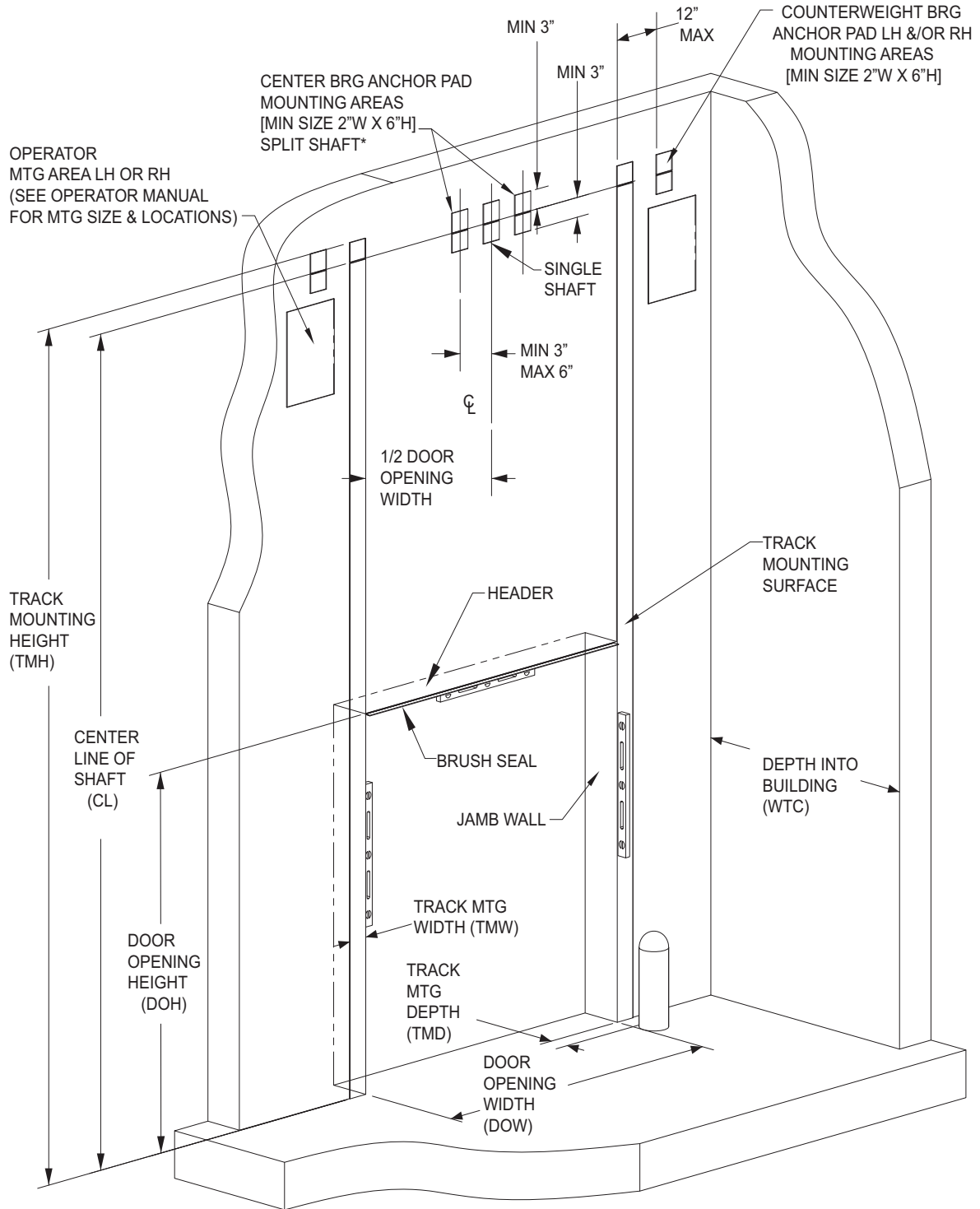

SPRING/SHAFT INSTALLATION

⚠ WARNING

Failure to assemble the Torsion Springs and Counterbalance System correctly will cause the door to function improperly and could result in death or serious injury.

COMPONENT IDENTIFICATION

1. Identify specific spring, shaft, and bearing kit required for selected door. See the Counter Balance PDS (Production Detail Sheet) from the Owner's Parts Book.
2. Inspect spring/shaft components for any missing or damaged items.
3. When viewing the door from the inside of the building, looking out, RED winding cone torsion springs/drums are installed on the left side of the door and BLACK winding cone torsion springs and drums are installed on the right side of the door.
4. Failure to install the torsion springs correctly will cause the door to function improperly and could result in serious injury. If door is to be equipped with a chain hoist or motor operator, a solid keyed shaft **MUST BE** used for shaft assembly.

SINGLE SPRING/SINGLE SHAFT ASSEMBLY

1. Layout counter balance parts on floor
2. Identify if spring is left hand (red) or right hand (black)
3. Slide center bearing(s) to the center of the shaft with the bearing race facing away from the selected spring.
4. Slide the left spring (red) on to shaft with the stationary spring cone facing the center of shaft and the winding cone to the outer.
5. Slide the right spring (black) on to shaft with the stationary spring cone facing the center of shaft and the winding cone to the outer.
6. Bolt spring stationary cone, center bearing(s), and center bearing bracket(s) together. **DO NOT** tighten completely, this will allow for adjustments with installation.
7. Slide the left drum (red) on the left side of shaft with the setscrews facing the center of the shaft.
8. Slide the right drum (black) on the right side of shaft with the setscrews facing the center of the shaft.
9. Slide on specified end bearings on to both ends of shaft with correct orientation. The bearing race has an outside diameter of 1-1/4" and projects from the flange 1/8". The bearing housing has an outside diameter of 2" and projects from the flange 3/8". The bearing race needs to be facing the cable drums.
10. Lift counterbalance assembly onto end bearing plates, making sure end bearing are positioned inside of plates with races facing inward.
11. Secure shaft and bearing to plate using carriage bolts supplied. Verify bearing position specified on IDS (Installer Detail Sheet) in the owner's parts book.
12. Slide drums against end bearing races. Insert the shaft key for each drum when a solid shaft with a keyway is being used.
13. Tighten the set screws as follows:
 - Solid Shaft: Do not exceed 1/2 turn after coming in contact with the shaft.
 - Hollow Shaft: Tighten set screws enough to dimple shaft, about 1-1/4 turns after set screws first hit shaft.

SPRING/SHAFT INSTALLATION (continued)

⚠ WARNING

Failure to assemble the Torsion Springs and Counterbalance System correctly will cause the door to function improperly and could result in death or serious injury.

SINGLE SPRING WITH SINGLE SHAFT

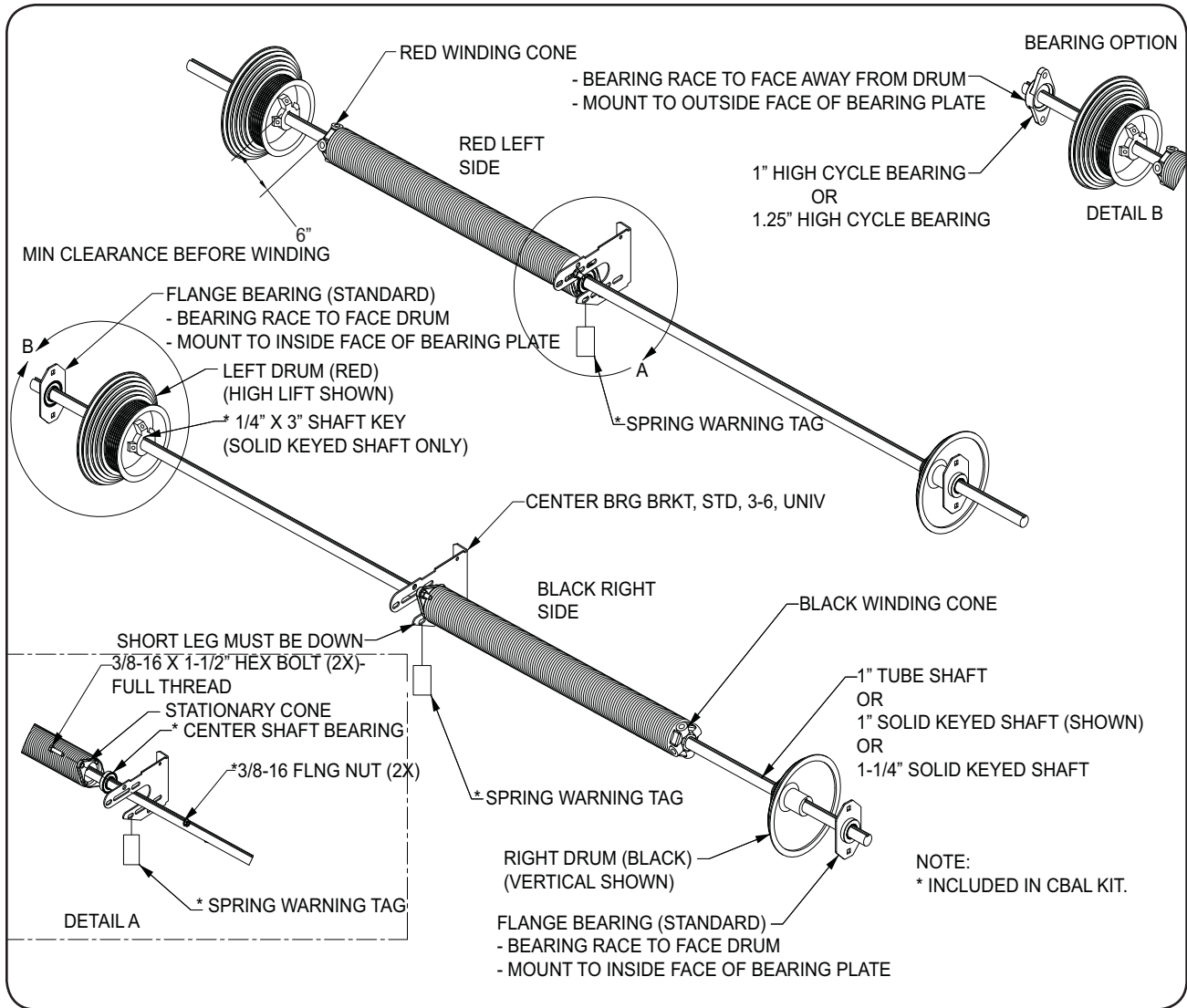

SPRING/SHAFT INSTALLATION (continued)

⚠ WARNING

Failure to assemble the Torsion Springs and Counterbalance System correctly will cause the door to function improperly and could result in death or serious injury.

DOUBLE SPRING/SINGLE SHAFT ASSEMBLY

1. Layout counter balance parts on floor
2. For 6" Springs - Slide the two center bearings to the center of the shaft with the bearing races facing each other.
3. For 2 5/8" or 3 3/4" dia Springs - Slide center bearing to the center of the shaft with the bearing race facing away from the selected spring.
4. Slide the left spring (red) on to shaft with the stationary spring cone facing the center of shaft and the winding cone to the outer.
5. Slide the right spring (black) on to shaft with the stationary spring cone facing the center of shaft and the winding cone to the outer.
6. Bolt spring stationary cones, center bearing, and center bearing bracket together. DO NOT tighten completely, this will allow for adjustments with installation.
7. Slide the left drum (red) on the left side of shaft with the setscrews facing the center of the shaft.
8. Slide the right drum (black) on the right side of shaft with the setscrews facing the center of the shaft.
9. Slide on specified end bearings on to both ends of shaft with correct orientation. The bearing race has an outside diameter of 1-1/4" and projects from the flange 1/8". The bearing housing has an outside diameter of 2" and projects from the flange 3/8". The bearing race needs to be facing the cable drums.
10. Lift counterbalance assembly onto end bearing plates, making sure bearings are positioned inside of the plates with races facing inward.
11. Secure shaft and bearing to plate using carriage bolts supplied.
12. Slide drums against end bearing races. Insert the shaft key for each drum when a solid shaft with a keyway is being used.
13. Prior to final tightening center bearing bracket, bolts and anchors, adjust the shaft to ensure it is running straight and level.
14. Tighten the set screws as follows:
 - Solid Shaft: Do not exceed 1/2 turn after coming in contact with the shaft.
 - Hollow Shaft: Tighten set screws enough to dimple shaft, about 1-1/4 turns after set screws first hit shaft.

SPRING/SHAFT INSTALLATION (continued)

⚠ WARNING

Failure to assemble the Torsion Springs and Counterbalance System correctly will cause the door to function improperly and could result in death or serious injury.

DOUBLE SPRING WITH SINGLE SHAFT

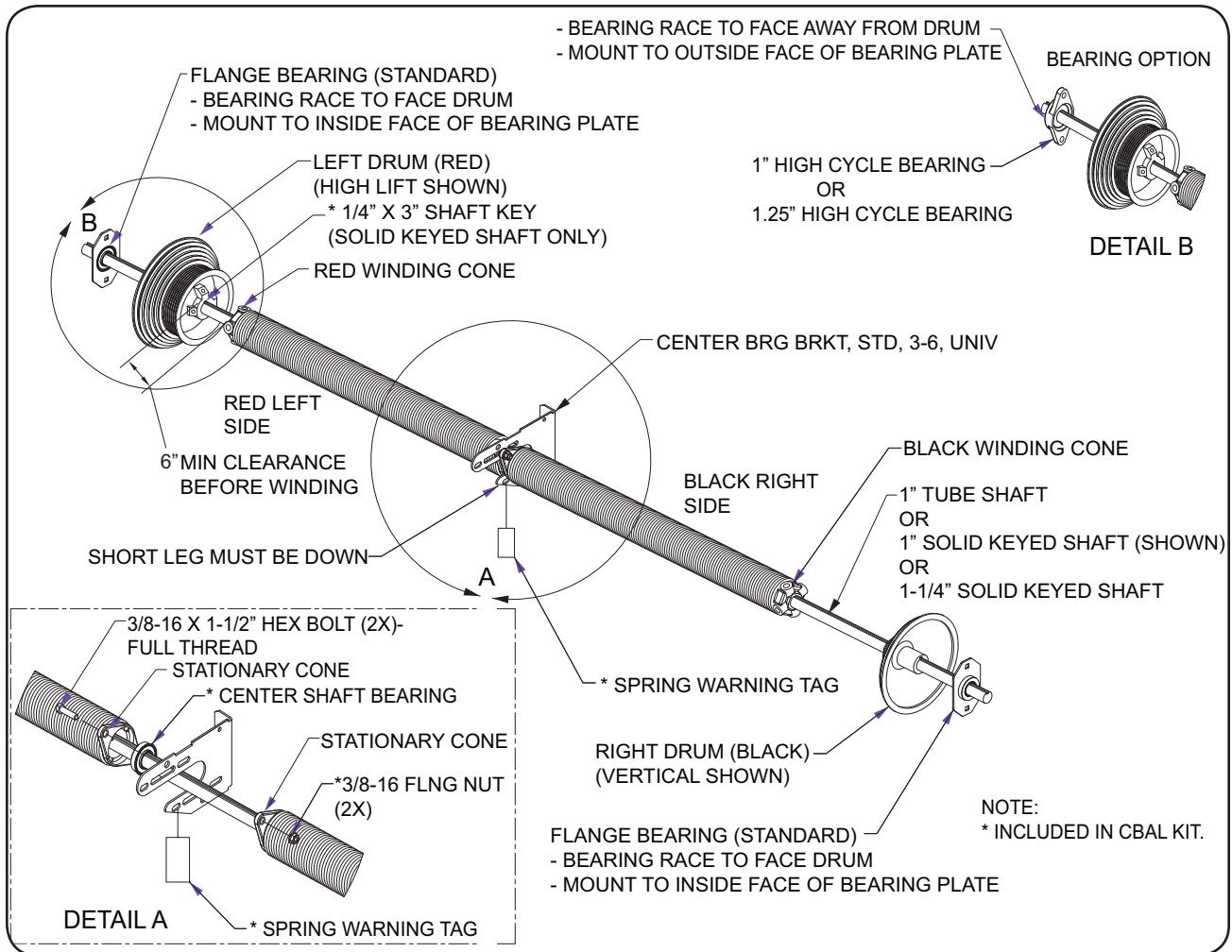

SPRING/SHAFT INSTALLATION (continued)

⚠ WARNING

Failure to assemble the Torsion Springs and Counterbalance System correctly will cause the door to function improperly and could result in death or serious injury.

DOUBLE SPRING/SPLIT SHAFT ASSEMBLY

1. Layout counter balance parts on floor
2. Slide each 1/2 of the coupler flush to the ends of the both shafts that will be mounted together in the center.
3. Install keys into shaft/coupler and tighten setscrews and locking nuts.
4. Coupler, shaft and key **MUST BE** flush. Both ends will be bolted together when installing spring assembly.
5. Slide center bearing on to each shaft with the race facing the coupler.
6. Slide the left spring (red) on to left shaft with the stationary spring cone facing the coupler. Slide the right spring (black) on to right shaft with the stationary spring cone facing the coupler.
7. Bolt spring stationary cones, center bearing, and center bearing bracket together. **DO NOT** tighten completely, this will allow for adjustments with installation.
8. Slide the left drum (red) on the left side of shaft with the setscrews facing the coupler.
9. Slide the right drum (black) on the right side of shaft with the setscrews facing the coupler.
10. Slide on specified end bearings on to both ends of shaft with correct orientation. The bearing race has an outside diameter of 1-1/4" and projects from the flange 1/8". The bearing housing has an outside diameter of 2" and projects from the flange 3/8". The bearing race needs to be facing the cable drums.
11. Lift counterbalance assembly onto end bearing plates, making sure bearings are positioned inside of the plates with races facing inward.
12. Secure shaft and bearing to plate using carriage bolts supplied.
13. Slide drums against end bearing races. Insert the shaft key for each drum when a solid shaft with a keyway is being used.
14. Prior to final tightening center bearing bracket, bolts and anchors, adjust the shaft to ensure its running straight and level.
15. Tighten the set screws as follows:
 - Solid Shaft: Do not exceed 1/2 turn after coming in contact with the shaft.
 - Hollow Shaft: Tighten set screws enough to dimple shaft, about 1-1/4 turns after set screws first hit shaft.

SPRING/SHAFT INSTALLATION (continued)

⚠ WARNING

Failure to assemble the Torsion Springs and Counterbalance System correctly will cause the door to function improperly and could result in death or serious injury.

DOUBLE SPRING WITH SPLIT SHAFT

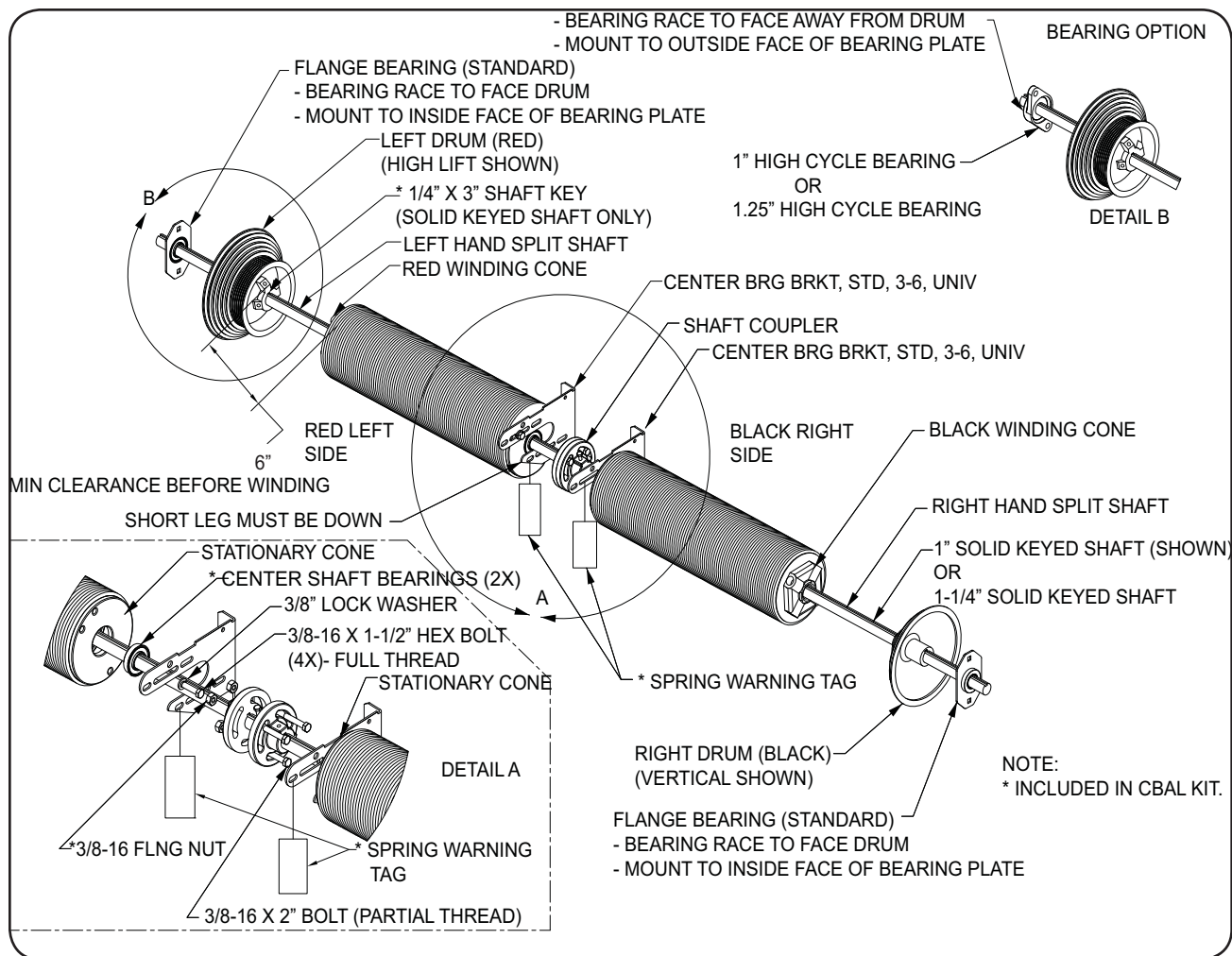

WINDING SPRINGS

⚠ WARNING

The Spring Assembly, which includes the Springs, Spring Anchor Brackets, Cables, Cable Drums and Bearing Brackets, is under extreme tension and if handled improperly, could result in death or serious injury. Spring Assemblies should ONLY be installed, adjusted or repaired by a trained door systems technician.

SECURE DOOR

1. Check stacked panels for level.
2. Verify that the cable attachment bracket is installed on the correct panel (see Installer Detail Sheet).
3. Securely lock door in down position to prevent door from opening while winding springs.

INSTALL CABLES

1. Position Left-Hand (red) drum to shaft, making sure that the drum is tight against the bearing race. Tighten drum to the shaft. If shaft is solid keyed, properly align drum/shaft and install shaft key prior to tightening.
2. Obtain cable that is attached to the left cable bracket on panel and run it up to the shaft between the wall and the drum. On straight vertical doors, attach cable to the outside hole of the cable attachment bracket.
3. Place cable stops in the notch in the backside of drum and turn the drum/shaft until all slack in cable is removed. Make sure cable is seated properly in the grooves of the drum.
4. Fasten locking pliers to the shaft with the handle braced against the wall to keep cables taut.
5. Position Right-Hand (black) drum tight against bearing race.
6. Obtain cable that is attached to the right cable bracket on panel and run it up to the shaft between the wall and the drum. On straight vertical doors, attach cable to the outside hole of the cable attachment bracket.
7. Place cable stops in the notch in the backside of drum and turn the drum until all slack in cable is removed. Make sure cable is seated properly in the grooves of the drum.
8. Tighten drum to shaft. If shaft is solid keyed, properly align drum/shaft and install shaft key prior to tightening. Each cable MUST have the same amount of pre-tension.
9. If split shaft is supplied, securely tighten shaft coupler bolts, set screws and locking nuts.

WIND SPRINGS

See parts book (Installer IDS sheet) for spring turns.

1. Clear the area of personnel and keep yourself out of the direct path of the winding bars while winding the torsion springs.
2. Use a sturdy ladder or platform to stand on and keep slightly to the side of the winding bars.
3. Mark horizontal chalk line across the entire length of spring(s). This will help indicate the number of turns placed on the torsion spring(s).
4. Insert the winding bars into the full depth of hole in the winding cone.

⚠ WARNING

The spring assembly, which includes the springs, spring anchor brackets, cables, cable drums and bearing brackets, is under extreme tension. Spring assemblies should ONLY be installed, adjusted or repaired by a trained door systems technician. Winding bars MUST fit snugly into the holes in the winding cone. NEVER use smaller rods or screwdrivers as winding bars. Failure to use proper winding bars could result in death or serious injury.

WINDING SPRINGS (continued)

WIND SPRINGS (continued)

5. Wind springs in an upward direction 1/4 turn and hold the tension.
6. Insert the second winding bar fully into the next available hole in the winding cone. Take the load on the second winding bar and remove the first winding bar.
7. Wind the second winding bar upward 1/4 turn. Always wind springs in 1/4 turn increments. Four 1/4 turns are required to obtain one full turn. The number of turns can be obtained by counting the turns of the chalk line.
8. Continue this procedure until the specified number of turns per spring is obtained. If tension in the torsion spring DOES NOT increase when adding 1/4 turn, the springs may be reversed. As the torsion springs are wound, the spring will grow longer. Allow winding cone to move outward as turns are applied to prevent "kinking" of spring wire.
9. When the last 1/4 turn has been completed, insert a second winding bar into the bottom hole of the winding cone and stretch springs outward 1/2" to 1". This will reduce the possibility of spring coils binding during operation.
10. Tighten setscrews on the winding cone with oiled threads to 15-16 ft-lbs. Follow the recommendations listed below to avoid exceeding the specified torque:
 - Solid Shaft: Do not exceed 1/2 turn after coming in contact with the shaft.
 - Hollow Shaft: Tighten set screws enough to dimple shaft, about 1-1/4 turns after set screws first hit shaft.
11. Make sure all springs are thoroughly oiled (around the entire circumference of the spring) with LightWeight oil or food grade equivalent.
12. Repeat this procedure for other spring. On doors with two springs, both springs should be wound the same amount of turns.

▲ WARNING

If any adjustment to the Upper Tracks has to be made, the door MUST BE locked in the closed position. If it is required to add or reduce the tension of the Torsion Springs, always use Winding Bars and stay clear to the side. Be prepared to handle the force of the Springs. NEVER adjust the Center Bearing Bracket after the Springs are wound.

Use caution when opening the door for the first time. If the Tracks are incorrectly mounted too wide, the door may fall out of the Tracks.

13. Install SPRING WARNING TAG as shown in the illustrations below.

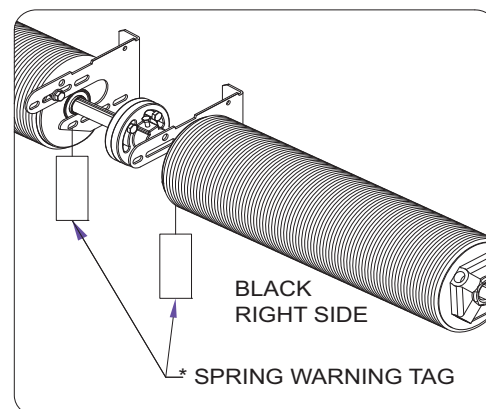
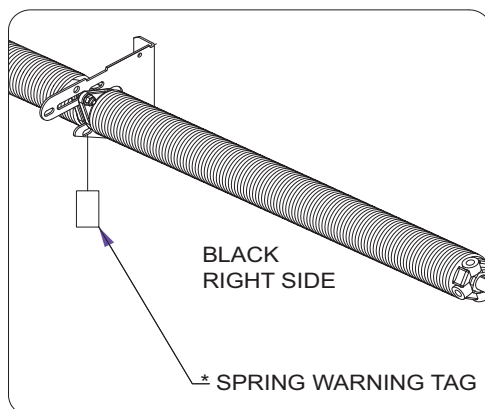

14. It is recommended that only Silicone Spray is applied to entire track system (lower, upper, radius, and horizontal tracks where plunger tips and side seals contact).
15. While securely holding down the door, unlock the door and slowly raise the door. It is recommended that ONLY Silicone Spray is applied to entire track system (lower, upper, radius and horizontal tracks where plunger tips and side seals contact).

WINDING SPRINGS (continued)

16. Remove locking pliers from shaft.

17. While securely holding down the door, unlock the door and slowly raise the door. Cycle door a few times to determine balance. Add or subtract tension as necessary to balance door to customer satisfaction.

18. When door is closed make sure that there is positive sealing around side and bottom seals. Track adjustment and/or leveling may be necessary to accomplish this. It is the installer's responsibility to make these adjustments before leaving the job site. It is the customer's responsibility to maintain this going forward.

⚠ WARNING

The Spring Assembly, which includes the Springs, Spring Anchor Brackets, Cables, Cable Drums and Bearing Brackets, is under extreme tension and if handled improperly, could result in death or serious injury. Spring assemblies should ONLY be installed, adjusted or repaired by a trained door systems technician.

SINGLE SHAFT (SHOWN WITH DUAL SPRING)

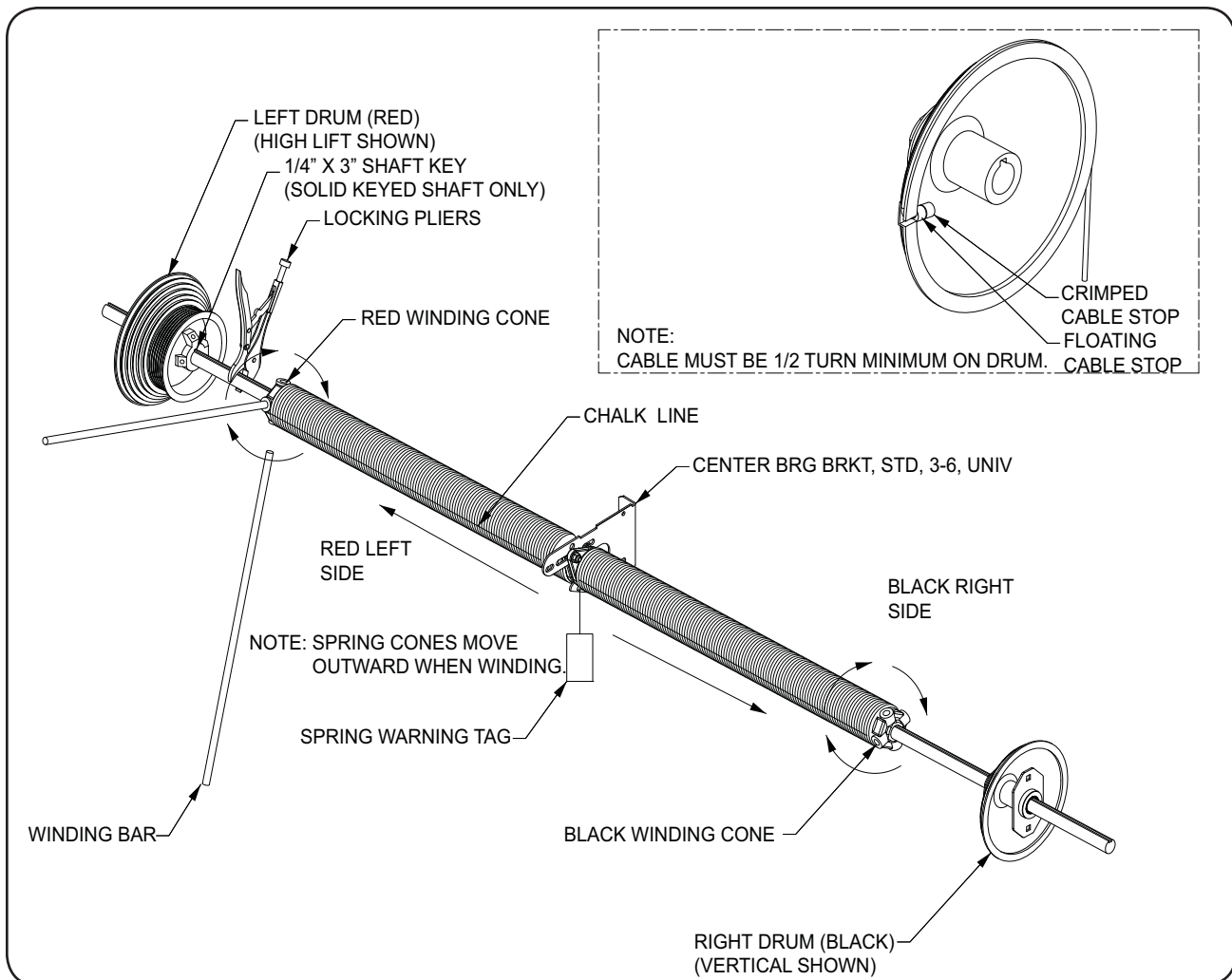

WINDING SPRINGS (continued)

⚠ WARNING

The Spring Assembly, which includes the Springs, Spring Anchor Brackets, Cables, Cable Drums and Bearing Brackets, is under extreme tension and if handled improperly, could result in death or serious injury. Spring assemblies should ONLY be installed, adjusted or repaired by a trained door systems technician.

SPLIT SHAFT (SHOWN WITH DUAL SPRING)

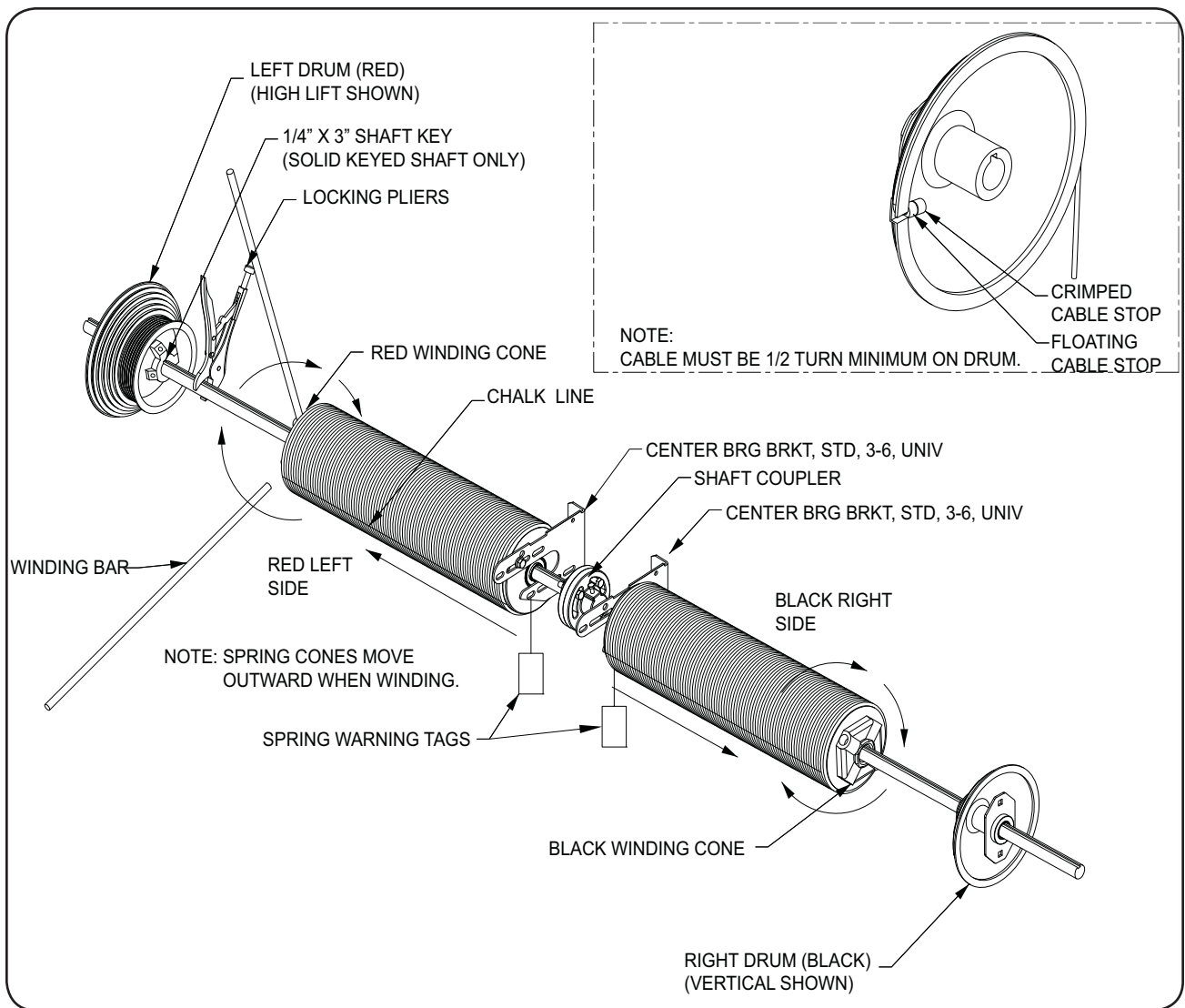

DOOR OPERATION

⚠ WARNING

Before operating the door, read and follow the Safety Practices on pages 4-5. Stand back. Moving door can crush you. Keep people clear while door is moving. Failure to follow these instructions could result in death or serious injury. NEVER try to open or close door until all Panel Plungers are reset back into Track and door has been inspected. NEVER climb under impacted Panels to reset door.

1. DO NOT operate door if it is not properly adjusted or free of obstructions.
2. NEVER operate door until the entire opening and track/guides are free of obstructions, equipment, material and people.
3. Keep hands clear of the tracks, hinges, springs and plungers at all times.
4. Lift and lower door with proper ergonomic methods by using supplied pull rope and door handles/step plates.
5. Raise and lower door slowly and maintain an even door travel speed. Keep door in full view. NEVER throw door up or pull door down at high speed.
6. DO NOT use the loading dock door if it looks broken or DOES NOT seem to work right. Tell your supervisor it needs repair right away.
7. Chock truck wheels or lock truck in place with a truck restraining device and set brakes before loading or unloading.
8. Keep door closed when not in use.
9. Move all equipment, material and people away from loading dock door and close dock door before allowing the truck to pull out.
10. DO NOT use a fork truck or other material handling equipment to raise or lower the loading dock door.

RESETTING IMPACTED PANELS

1. In the event of a panel KNOCK-OUT or track impact situation, step away from the door a safe distance.
2. Inspect the door system **BEFORE** resetting panels.
 - Plungers of the top panel **MUST BE** engaged in track.
 - Cables **MUST BE** properly tensioned and seated in the grooves of the cable drums.
 - Panels **MUST BE** sitting level with hardware intact.
 - Tracks **MUST BE** square to jamb face and securely mounted.If the above conditions are met, continue with resetting door (see steps 3-6 below). If any of these conditions are not met, **DO NOT** use door. Stay clear of door and immediately report incident to supervisor and have a trained door systems technician inspect and reset door.
3. Clear fork truck and/or all products from dock door area.
4. Grab manufacturer-supplied handle(s) and pull door panels back into tracks. If the spring plunger tips are obstructed at any point of the return travel, the plunger rods may be manually retracted while pulling panels back into tracks. Depending on conditions, this operation may require 2 people to safely reset the door.
 - **NEVER try to open or close door until all panel plungers are reset back into track and door has been inspected.**
 - **NEVER climb under impacted panels to reset door.**
5. Check panels, track, hardware and fasteners for any damage, looseness, misalignment, and verify track spacing **BEFORE** operating door.
6. After panels have been engaged back into the tracks, carefully cycle the door to its fully open and closed position several times making sure operation is smooth throughout its entire travel cycle.

AVAILABLE OPTIONS

- Anti-Drift Up Lock Kit for Single Knockout Track
- Knockout Lock Kit
- Pilfer Proof Cable Lock Kit

ANTI-DRIFT UP LOCK KIT FOR SINGLE KNOCKOUT TRACK

ITEM NO.	QTY	PART NO.	DESCRIPTION
1	2	30-00012	BUMP LOCK,SKO,STUD
2	2	10-00005	NUT, FLNG, 1/4-20

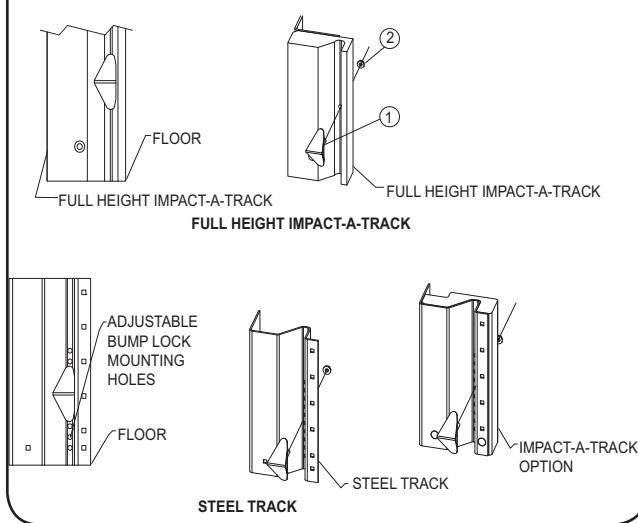

KNOCKOUT LOCK KIT

ITEM NO.	QTY	PART NO.	DESCRIPTION
1	1	20-00390	KNOCK-OUT LOCK PIN
2	1	10-00215	KNOCK-OUT LOCK PULL RING
3	1	10-00131	KNOCK-OUT LOCK LANYARD

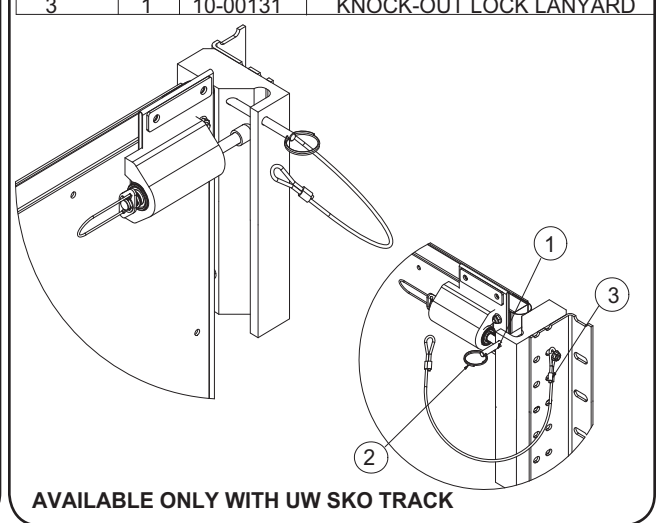

PILFER PROOF CABLE LOCK KIT

ITEM NO.	QTY	PART NO.	DESCRIPTION
1	2	30-00116	CABLE, PILFER PROOF
2	2	10-00026	BOLT, CRG, 1/4-20X3/4"
3	2	10-00005	NUT, FLNG, 1/4-20
4	2	10-00029	BOLT, CRG, 1/4-20X2-3/4"
5	2	10-00057	SCREW, PFH, 5/16-18X3"
6	2	10-00180	NUT, FLNG, TRILOK, NOSR, 5/16-18

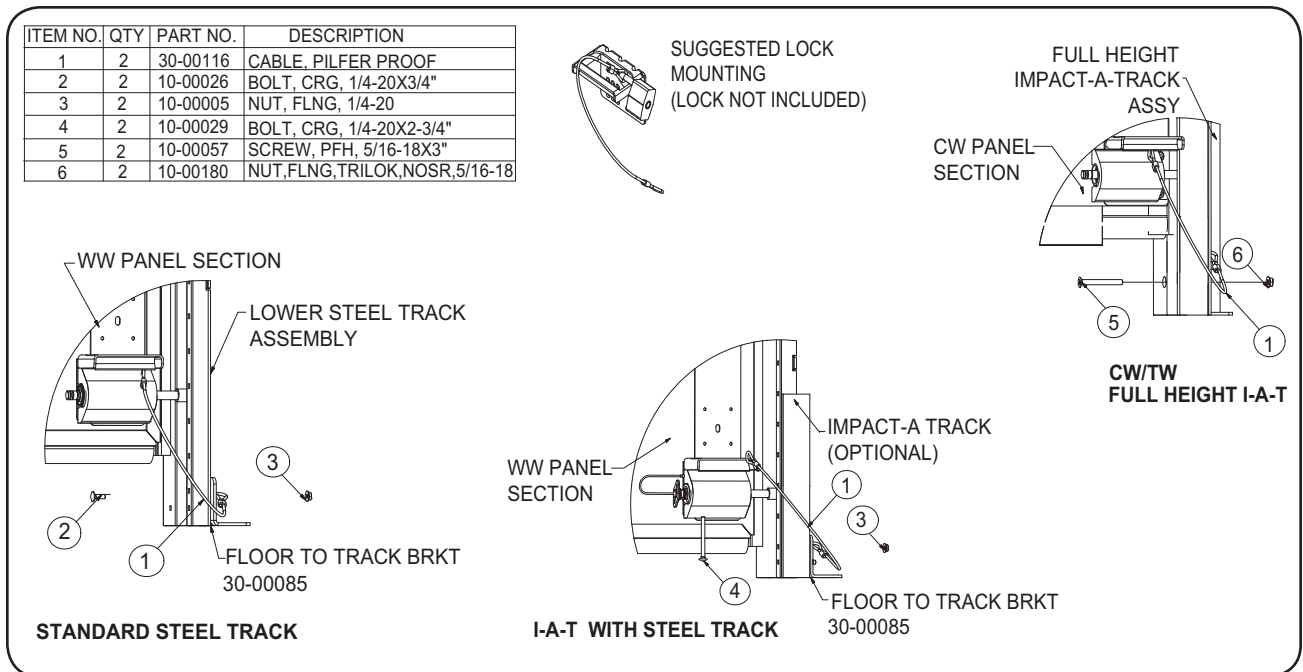

AVAILABLE OPTIONS (continued)

- Blade Weather Seal Kit for Header
- Anti-Drift Down Brush Kits for STL Track and FH I-A-T

BLADE WEATHER SEAL KIT FOR HEADER

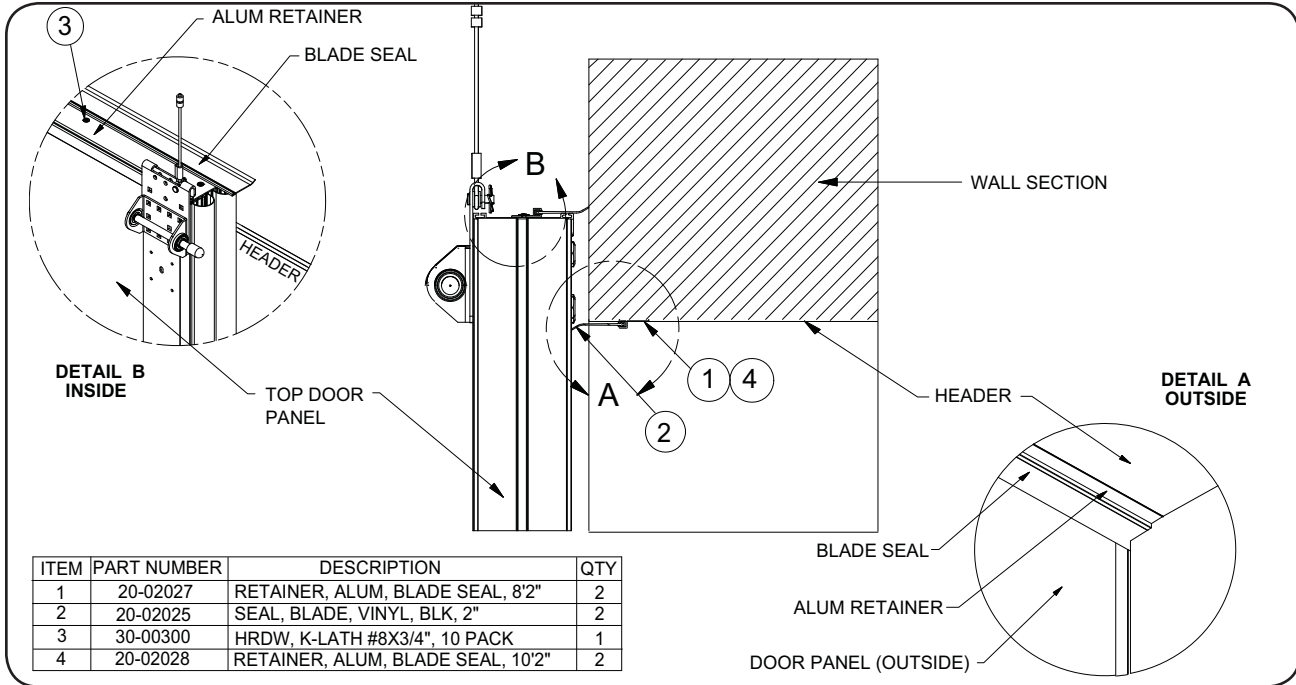

ANTI-DRIFT DOWN BRUSH KITS FOR STL TRACK AND FH I-A-T

ITEM	QTY	PART NUMBER	DESCRIPTION
1	2	20-02007	RETNR, LRG, #7, STR, ML 11.38"
2	2	20-02008	RETNR, LRG, #7, 90D, ML 11.38"
3	2	20-02009	BRUSH, LRG, #7, 1.50", BLK-10.63"
4	5	10-00334	SCREW, SLT HEX HD SP #8 X 1/2
5	3	10-00335	SCREW, SOC HD CAP, 1/4-20X3/4" BLK
6	3	10-00005	NUT, FLNG, 1/4-20

NOTES:

- ITEM NO.S 1,3,5, AND 6 ARE INCLUDED IN TKO PART NO. 30-00876- ANTI-DRIFT DOWN BRUSH KIT STL TRACK.
- ITEM NO.S 2,3, AND 4 ARE INCLUDED IN TKO PART NO. 30-00877- ANTI-DRIFT DOWN BRUSH KIT FH I-A-T.

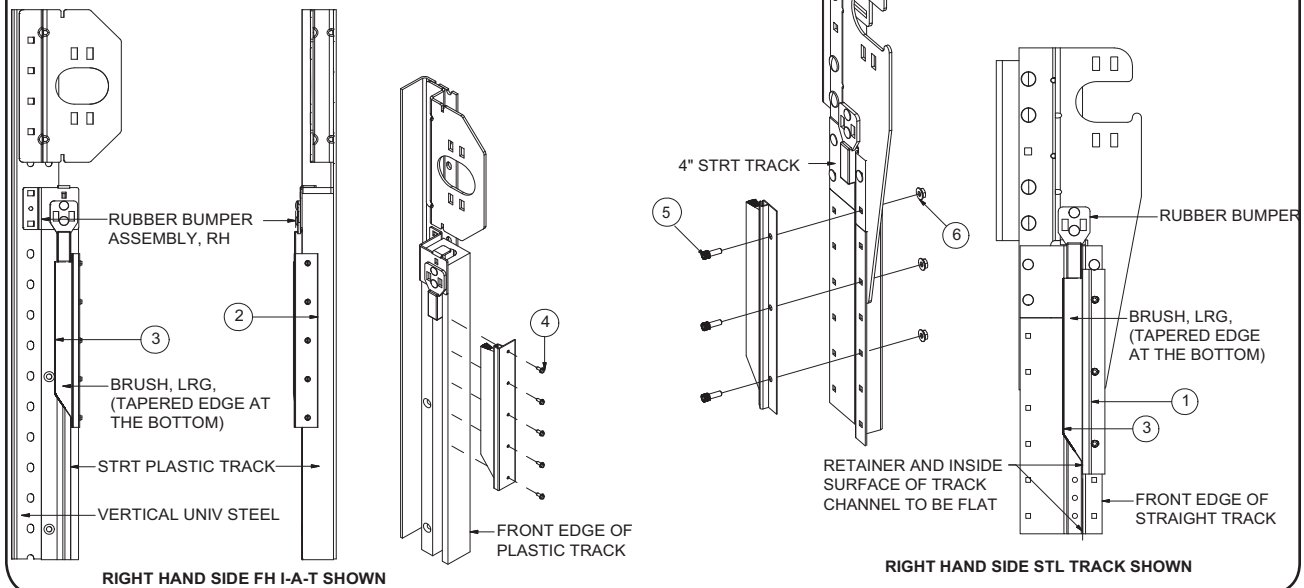

PLANNED MAINTENANCE

⚠ WARNING

Before servicing the door, read and follow the Safety Practices on pages 4-5 and the operations section of this manual. DO NOT attempt to repair or adjust door components unless you are a qualified door technician. Springs, Cable Brackets, Cables, Drums, Plungers, Supports and their hardware are under extreme tension and can cause injuries if not properly handled. Always follow the maintenance schedule to ensure all components are in good working condition. Damaged or worn parts MUST BE replaced immediately for proper and safe operation. It is recommended that the door be made inoperative until the damaged or worn parts have been replaced. Observe OSHA requirements for “LOCKOUT” or “TAGOUT” when performing work on the door. Disconnect power before performing maintenance or repair of electrical devices. Use proper tag or lockout procedures per OSHA regulations.

MAINTENANCE SCHEDULE

ITEM	PROCEDURE	INSPECT INTERVALS		
		Daily	Monthly	Every 3 Months
Operation	Manually operate the door. Check for smooth operation and proper balance. If this door has an automatic opener, disconnect it before this inspection.	•		
Labels	Inspect all safety/warning/product labels, placards, decals, tags. Replace if damaged or missing (See pgs. 53-55).		•	
Drums, Couplers, Sprockets	Check all set screws and shaft keys and securely tighten. Level door in opening if necessary.			•
Cables	Check for signs of abnormal wear, fraying or damage.			•
Bearings	Check for signs of abnormal wear or damage.			•
Cable Attachments	Check for signs of abnormal wear or damage and properly secure all fasteners.			•
Springs	Check for signs of abnormal wear or damage. Lubricate with lightweight oil, remove excess with shop rag. ♦.			•
Spring Anchors	Check for signs of abnormal wear or damage and properly secure all fasteners.			•
Shaft	Check for signs of abnormal wear or damage.			•
Track	Check for proper track spacing and alignment.		•	
Track	Check and properly secure all track anchors.			•
Track	Check for signs of abnormal wear or damage.	•		
Safety Spreader Bar	Check Safety Spreader Bar Assemblies (for High Lift and Tilt doors) are installed and undamaged.			•
Backhangs/ Sway Braces	Check for signs of abnormal wear or damage and properly secure all fasteners.			•
Plunger shafts and bearings	Check for signs of abnormal wear or damage. Verify shafts on Spring Plungers retract inside bearings by pulling on handles. NOTE: If shaft does not retract replace Plungers. Lubricate Spring Plungers by removing cover, lubricate shaft, bearings and springs with lightweight oil, slide back shaft, by pulling on handle while holding shaft in retracted position, lubricate shaft areas that are normally hidden by the bearings. ♦.			•
Hinges	Check for signs of abnormal wear or damage.			•
Fasteners	Check and properly secure all fasteners.			•
Panels	Check for signs of abnormal wear or damage.	•		
Panels	Clean with soap ONLY. Call TKO for approved cleaners ♣.	As Needed		
Seals	Check for signs of abnormal wear or damage.			•

♦ Use Light Weight Oil.

♣ Caution: Solvents may damage the panels and void manufacturers warranty.

TROUBLE SHOOTING

⚠ WARNING

Before servicing the door, read and follow the Safety Practices on pages 4-5 and the Door Operation section on page 71 of this manual.

TROUBLE SHOOTING GUIDE

TROUBLE	PROBABLE CAUSE	REMEDY
Door raises hard, closes easily	Insufficient counterbalance Springs need lubrication	Increase spring tension. Lubricate springs.
Door closes hard, raises easily	Too much counterbalance	Decrease spring tension.
Door jumps from floor	Too much counterbalance	Decrease spring tension.
Door lifts unevenly, light shows on one side of track	Door improperly leveled/ sitting crooked	Slip drums/shaft coupler or use cable leveling assemblies (top pickup doors) to level door.
Door will not stay open	Broken spring Insufficient counterbalance	Replace Spring. Increase spring tension.
Door operates with too much resistance	Springs need lubrication Broken spring Tracks are too tight or Grease/ Residue on tracks	Lubricate springs. Replace Spring. Adjust tracks to correct width. Wipe residue off seals. Lubricate all track running surfaces with a light coat of Silicone Spray. (DO NOT use oil or grease)

PARTS LISTING

⚠ WARNING

Fixed plungers are required on the Fourth and Higher panels when the counterbalance cable attachment is NOT at the top of the door.

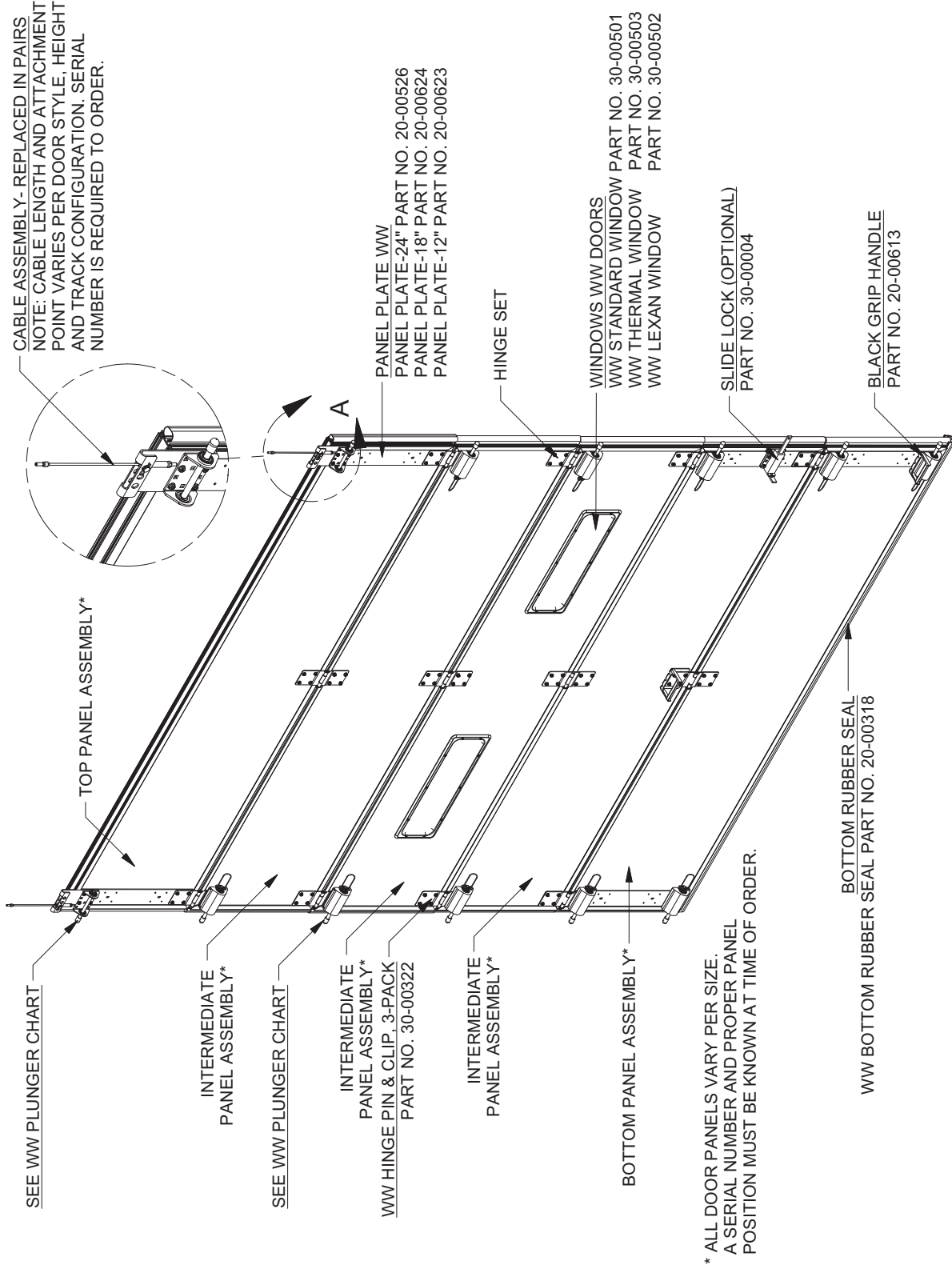

DOOR SERIAL NUMBER OR TRACK SPACING DIMENSION IS REQUIRED FOR CORRECT REPLACEMENT PART.

PARTS LISTING

⚠ WARNING

Fixed plungers are required on the Fourth and Higher panels when the counterbalance cable attachment is NOT at the top of the door.

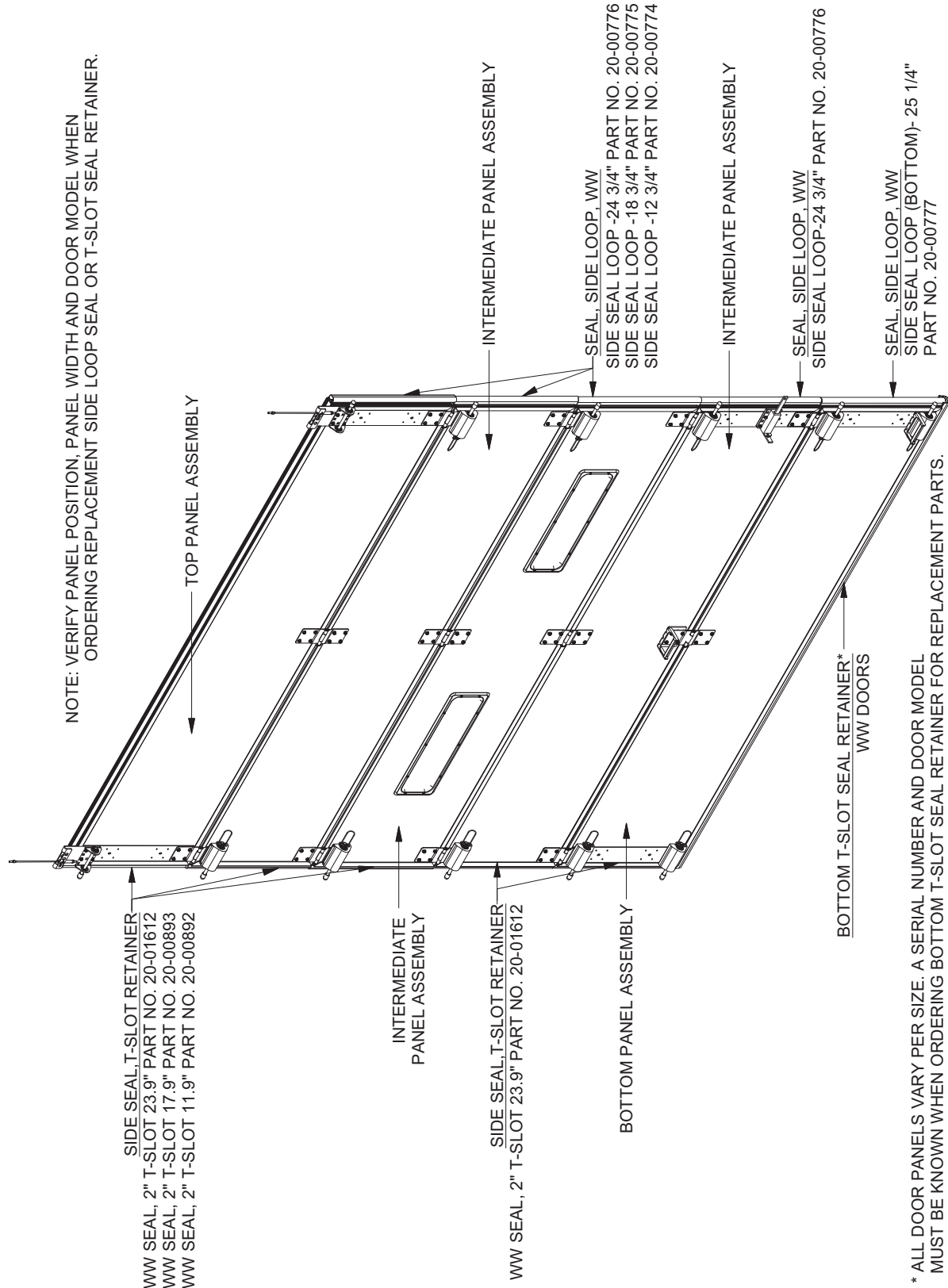

PARTS LISTING

STEEL TRACK ASSEMBLY PARTS (STRAIGHT VERTICAL TRACK SHOWN)

NOTE: MANY TRACK CONFIGURATIONS EXIST WITHIN EACH DOOR MODEL LINE.
A SERIAL NUMBER AND DOOR MODEL IS REQUIRED WHEN ORDERING TRACK
COMPONENTS. CONSULT FACTORY FOR SPECIFIC TRACK CONFIGURATION
AND PARTS IDENTIFICATION FOR YOUR SPECIFIC COMPONENT NEED.

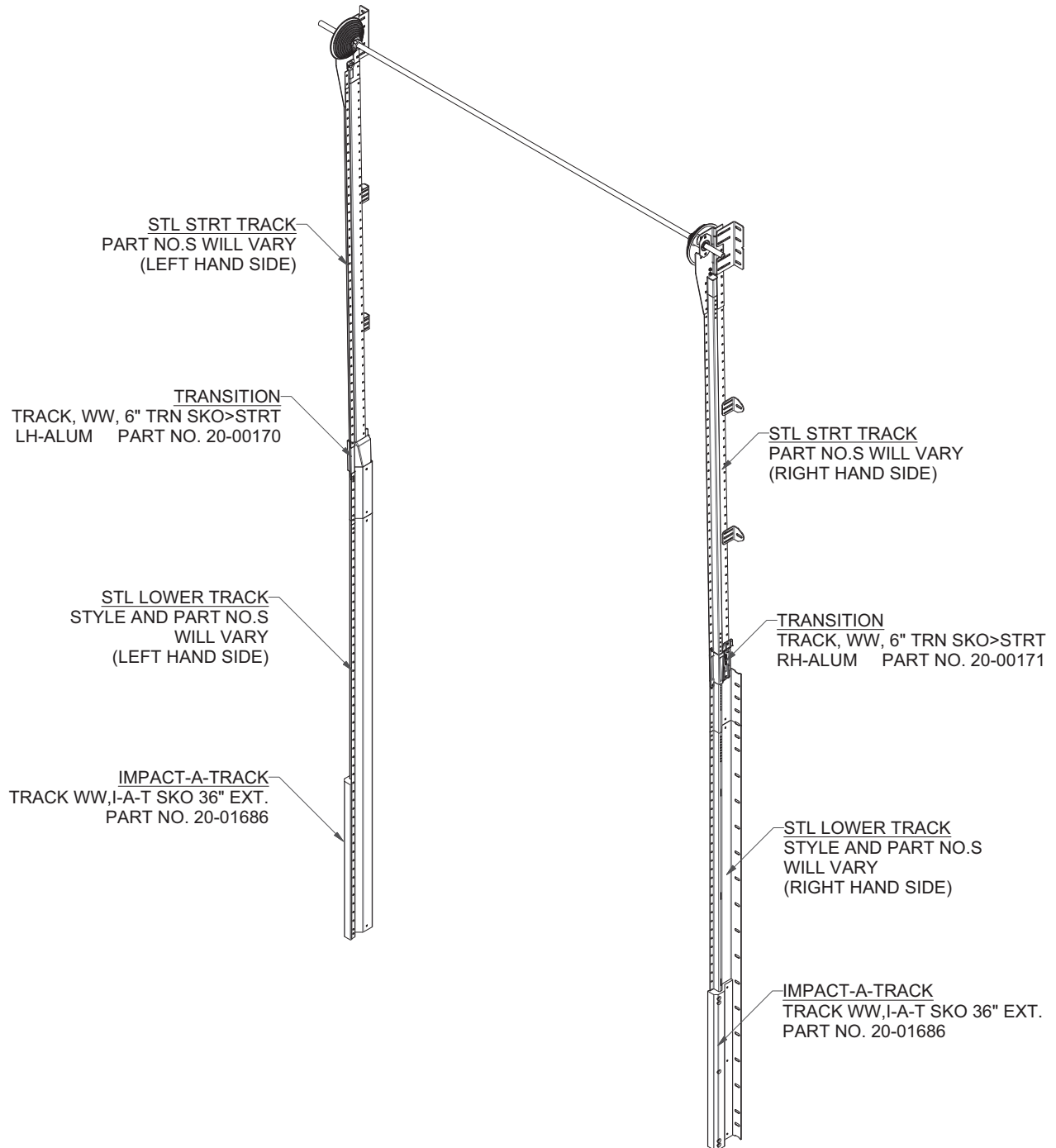

PARTS LISTING

UW TRACK ASSEMBLY PARTS (STRAIGHT VERTICAL TRACK SHOWN)

NOTE: MANY TRACK CONFIGURATION EXIST WITHIN EACH DOOR MODEL LINE. A SERIAL NO. AND DOOR MODEL IS REQUIRED WHEN ORDERING TRACK COMPONENTS. CONSULT FACTORY FOR SPECIFIC CONFIGURATION AND PARTS IDENTIFICATION FOR YOUR SPECIFIC COMPONENT NEED.

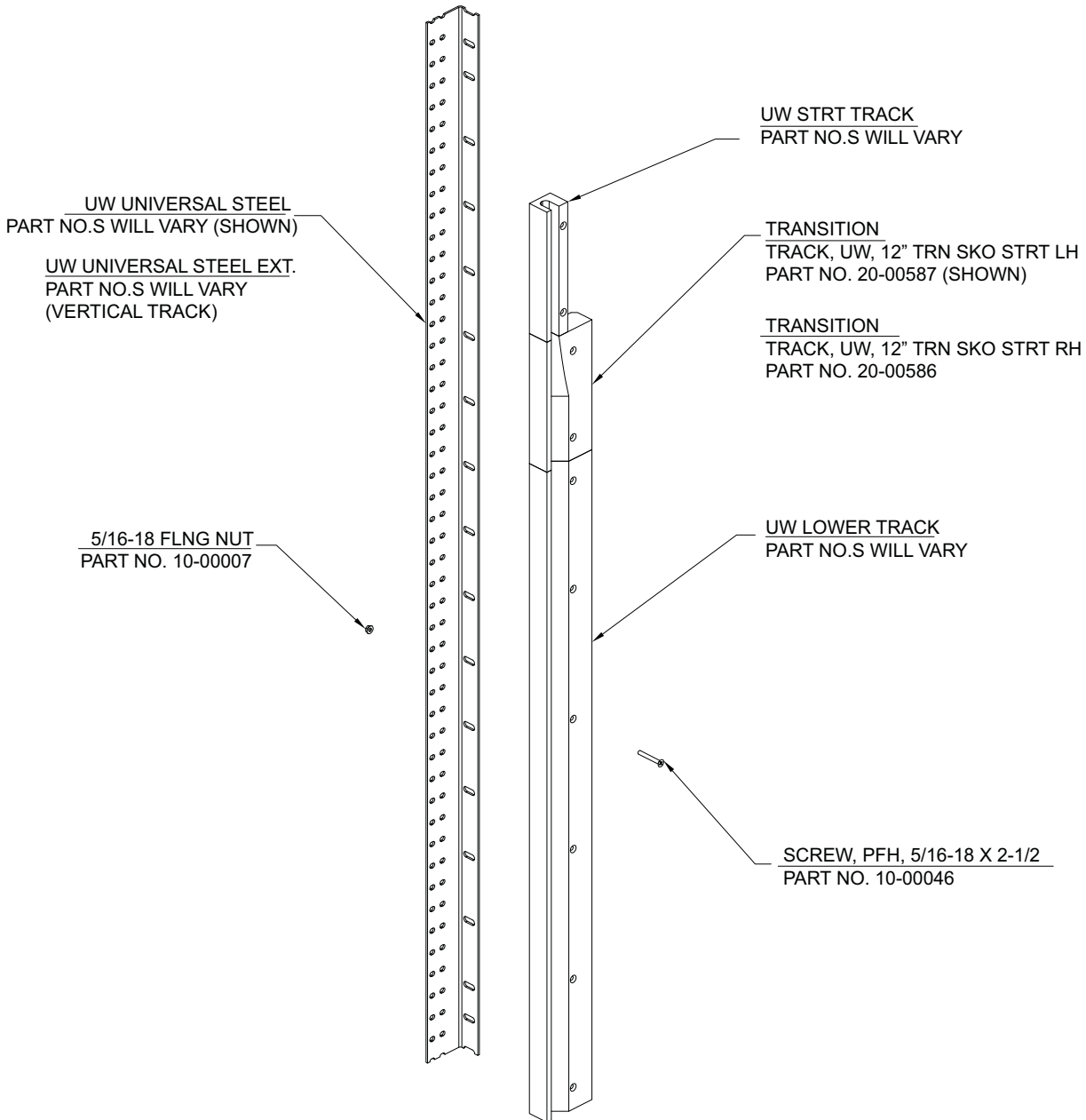

LEFT HAND SIDE SHOWN

DOOR SERIAL NO. OR TRACK SPACING DIMENSION REQUIRED
FOR CORRECT REPLACEMENT PART.



NOTES:



N56 W24701 Corporate Circle • Sussex, Wisconsin 53089. USA
Tel: 262-246-1300 • Fax: 262-246-1301 • Web: www.tkodoors.com

© 2012 4Front Engineered Solutions, Inc.